











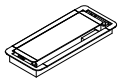

# Assembly Instructions

## QTJ-M608

<b>A</b>  Cam lock <b>32Pcs+1Pc(spare)</b>	<b>B</b>  Klix Cam <b>32Pcs+1Pc(spare)</b>	<b>C</b>  Cam Cover <b>32Pcs+1Pc(spare)</b>	<b>D</b>  M4*30 <b>16+1Pcs</b>	<b>F</b>  Screw Ø6*16 <b>32Pcs+1Pc( spare)</b>	<b>G</b>  Screw Ø6*45 <b>4Pcs</b>	<b>H</b>  L-bracket <b>8Pcs</b>	<b>J</b>  Grommet <b>1Pcs</b>
<b>K</b>  Leveler <b>7Pcs</b>	<b>L</b>  Screw M4*16 <b>2Pcs</b>	<b>M</b>  Screw Ø6*35 <b>4Pcs</b>	<b>N</b>  Ø4 <b>1Pcs</b>				

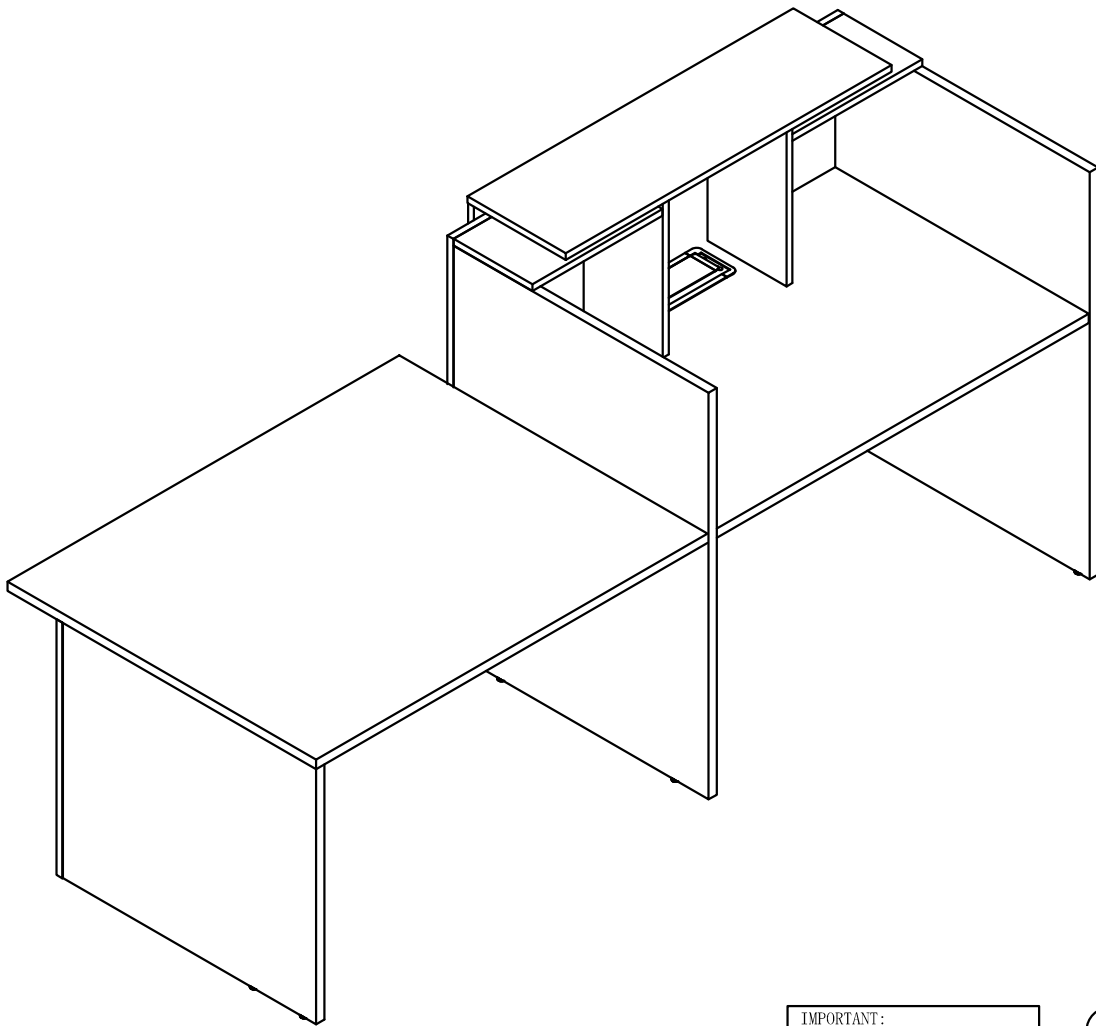

**IMPORTANT:**  
**FUNCTION OF KLIX CAM**



1/4 RIGHT  
 TURN FOR  
 LOCKING

MAKE SURE THE ARROW IS  
 POINTING UPWARDS BEFORE  
 INSERTING INTO THE PANELS  
 HOLE

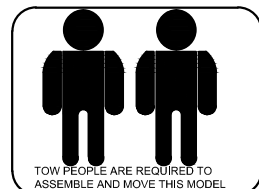

### IMPORTANT NOTE:

Place all laminated parts on a clean and smooth surface such as a rug or carpet to avoid the parts from being scratched.

Check to be sure that you have all parts and hardware.

Remove all wrapping materials, including staples & packing straps before you start to assemble.

Don't tighten all screws/bolts until all completely assembled.

Keep all hardware parts out of reach of children

# Assembly Instructions

## QTJ-M608

### STEP 1

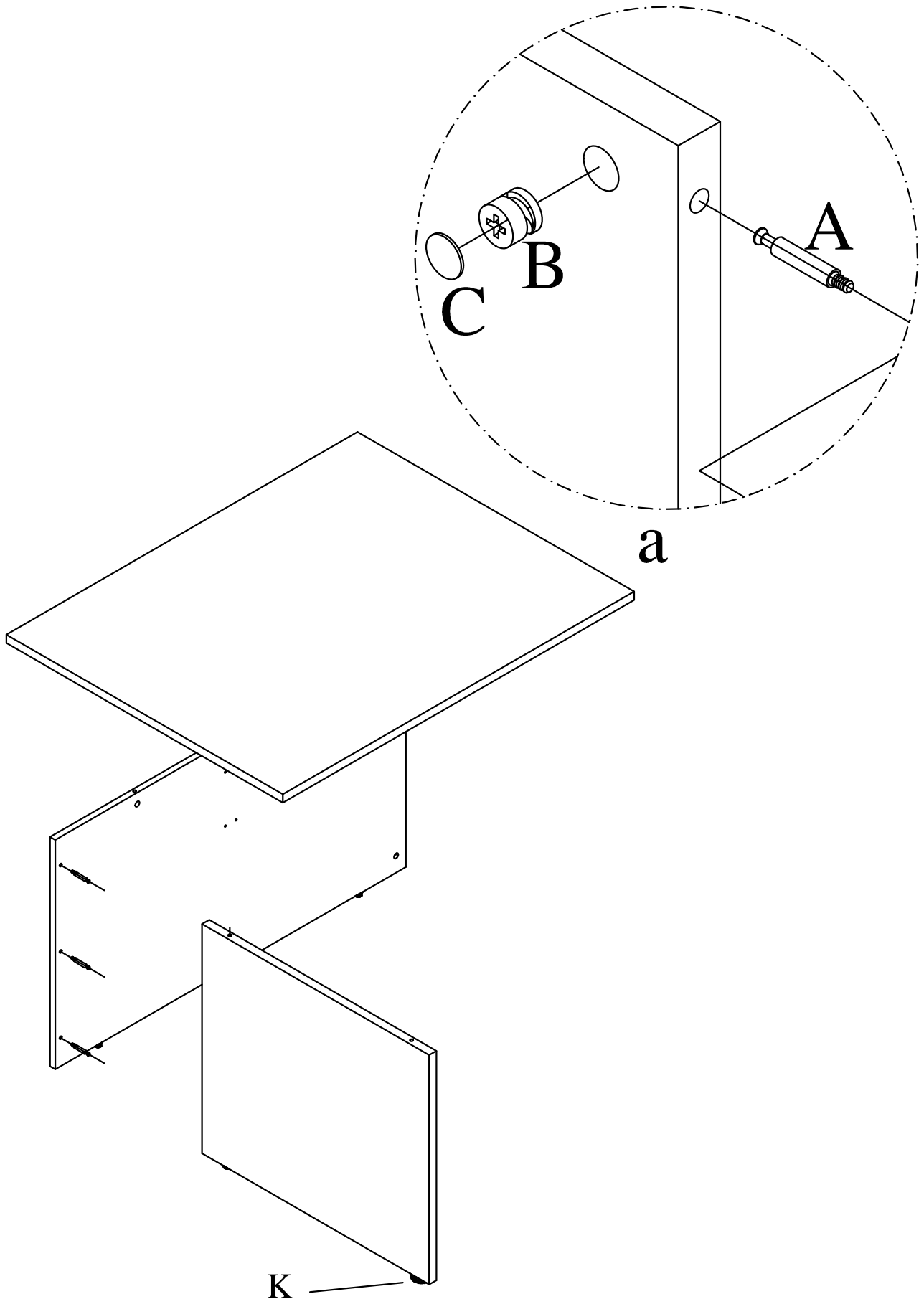

# Assembly Instructions

## QTJ-M608

### STEP 3

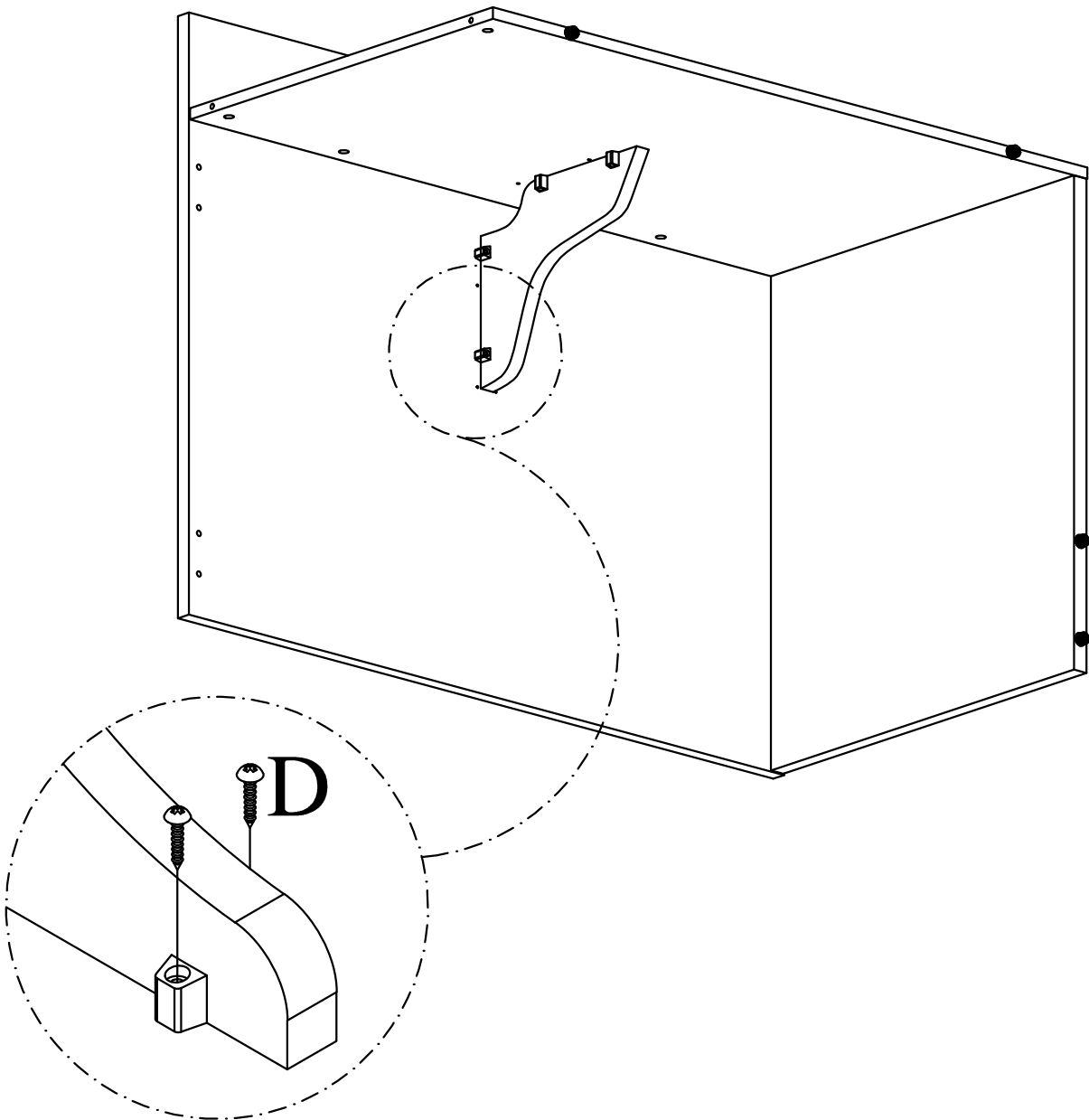

# Assembly Instructions

## QTJ-M608

### STEP 3

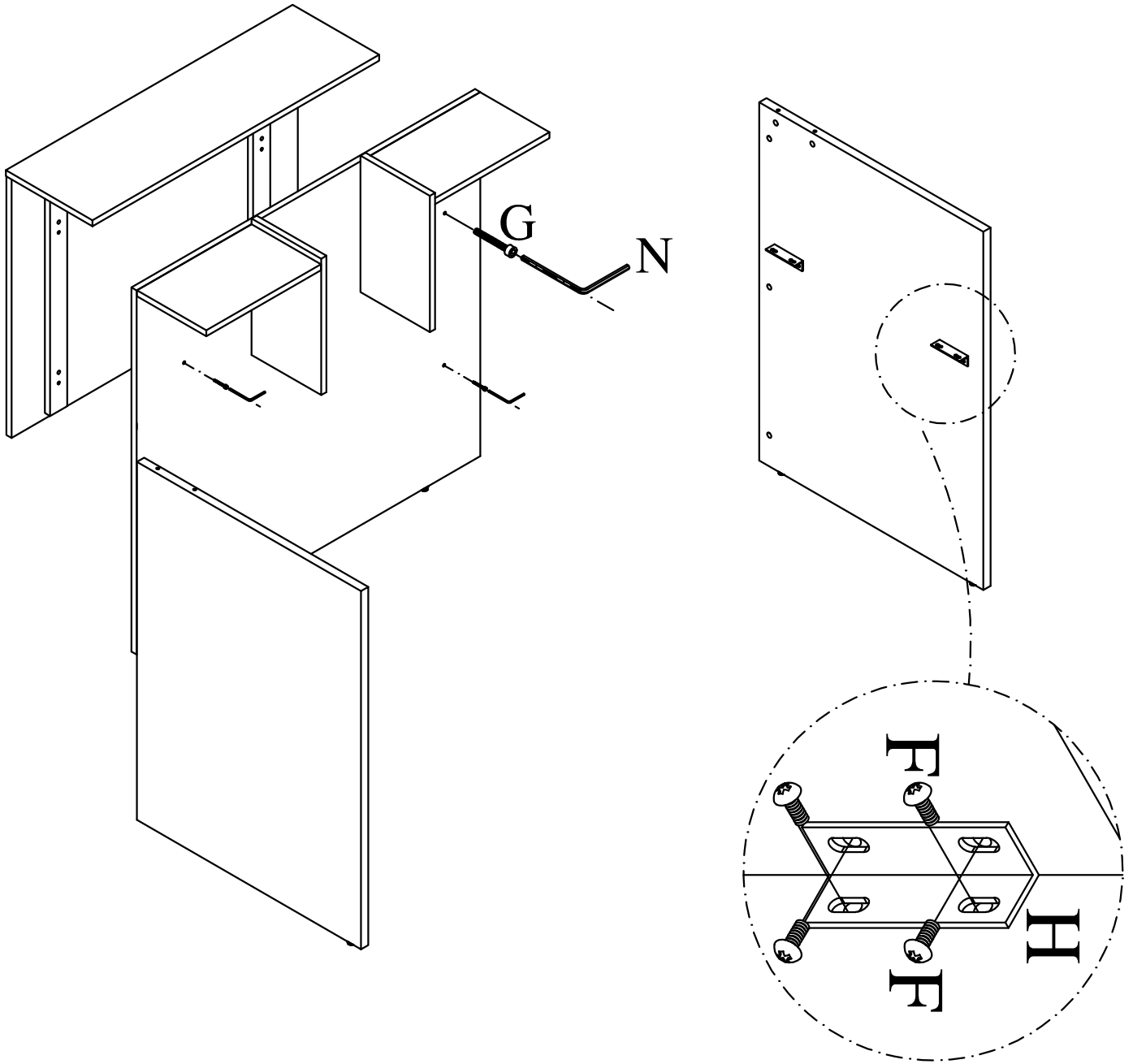

# Assembly Instructions

## QTJ-M608

### STEP 3

