

OPTIONAL FIXING TABS SHOWN BELOW

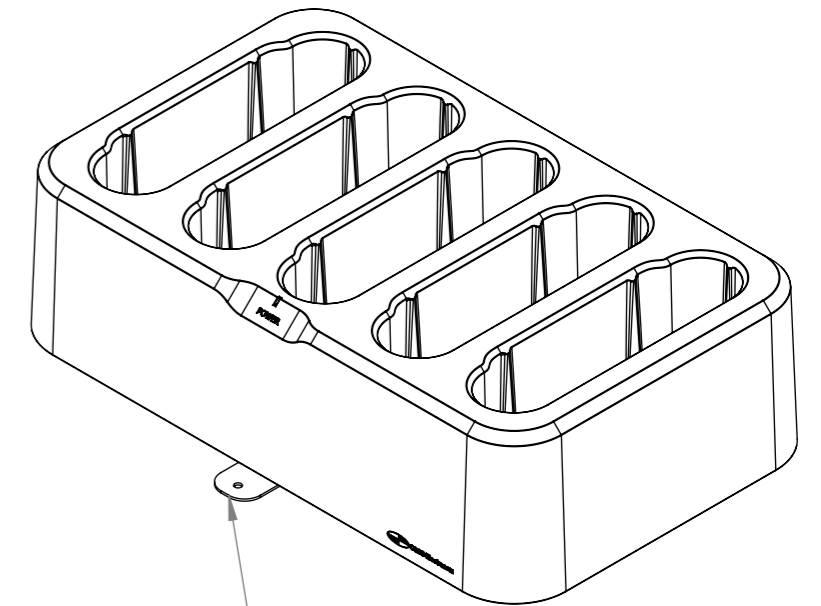

AVAILABLE WITH OPTIONAL FIXING TABS

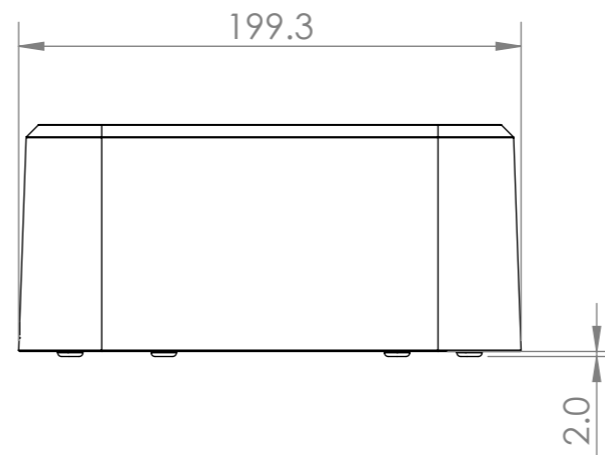
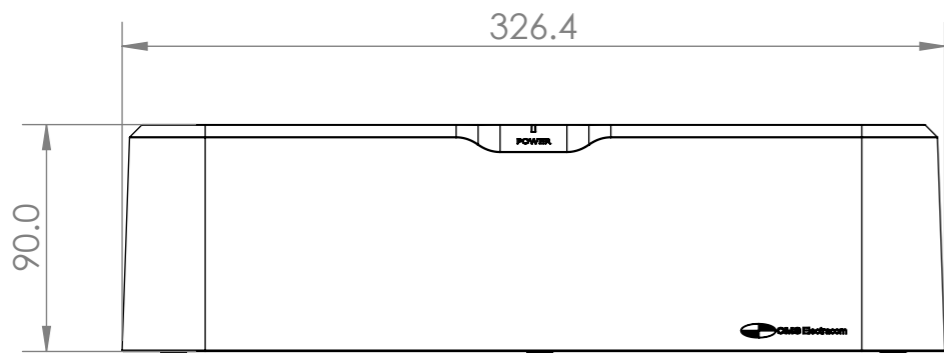
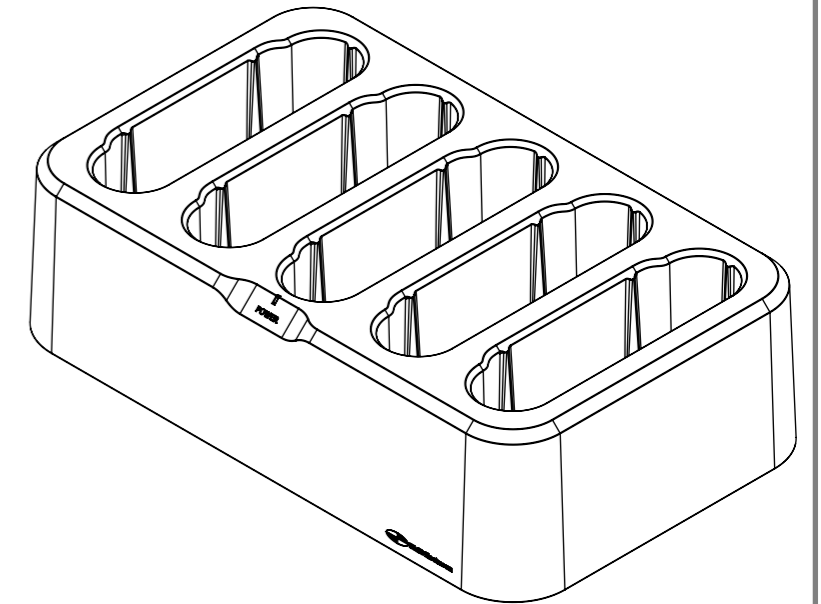
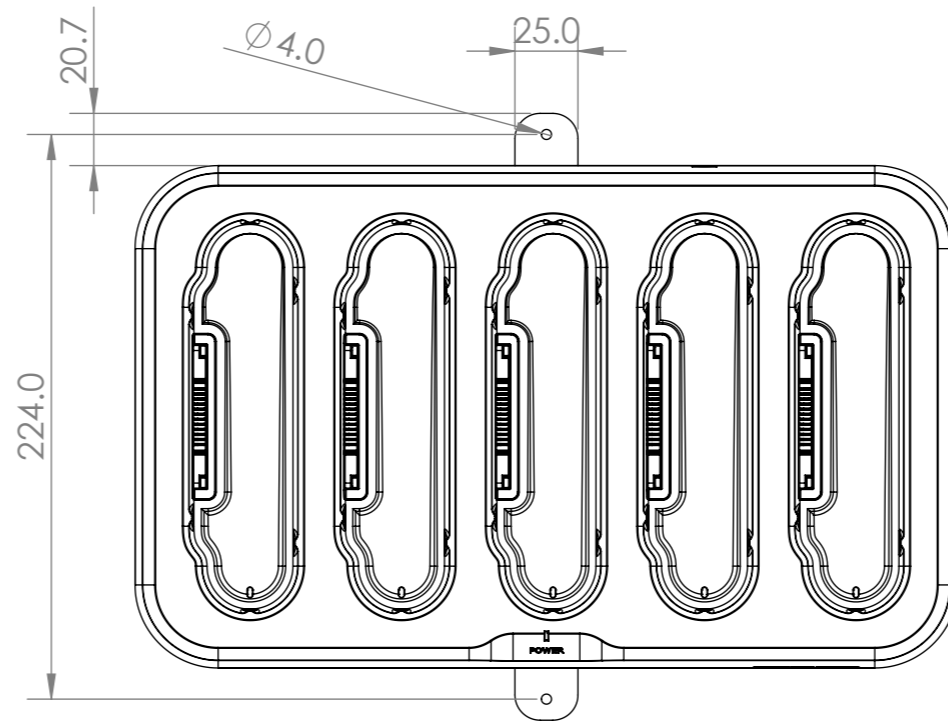
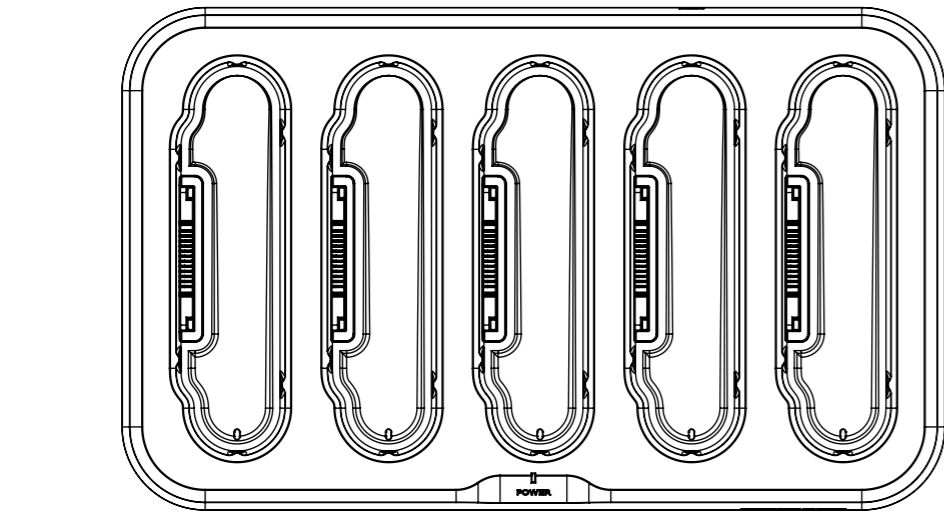
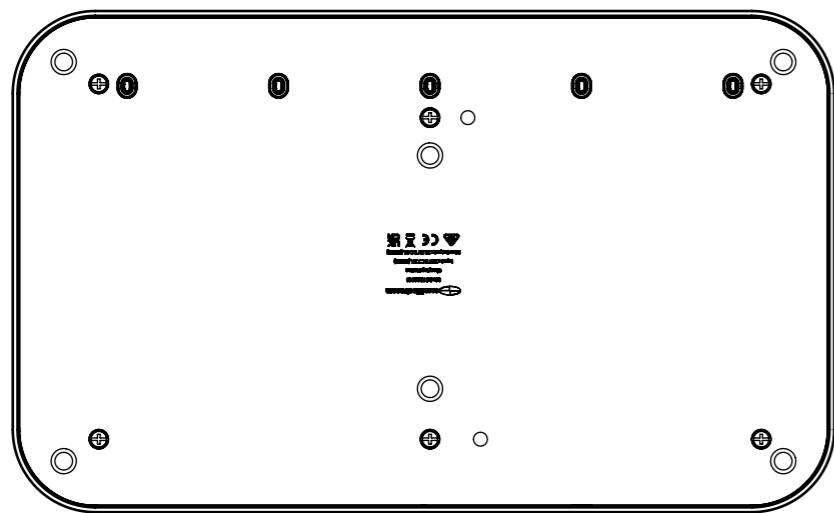

WEIGHT: 1.88KG

PART NUMBER: FR210CSxxXX

NOTE - xx - LEAD TYPE - REFER TO PURCHASE ORDER
XX - COLOUR - WHITE OR BLACK

REV	DESCRIPTION	DATE	DRWN	APPV
6	OPTIONAL FIXING TABS ADDED	15/8/2023	JB	RG
5	BOM ITEM 3 PART NAME UPDATED	4/7/2023	JB	RG
4	POWER SUPPLY ADDED TO BOM	13/6/2023	JB	RG
3	BOM UPDATED TO INCLUDE NEW PART + ADDITIONAL SCREWS	17/4/2023	JB	RG
2	BOM UPDTAED	31/10/2022	JB	RG
1	RELEASED FOR PRODUCTION	21/2/2022	JB	RG
REVISIONS				

CUSTOMER SIGNATURE:	TOLERANCES UNLESS OTHERWISE STATED: X ±0.5 X.X ±0.2 X.XX ±0.1 X.XXX ±0.05 ANG ±0.5°
MATERIAL: PC FR	
FINISH: FINE EDM / POWDERCOAT	
COLOUR: WHITE / BLACK	THIS DRAWING & ASSOCIATED CAD FILES ARE ISSUED IN THE STRICTEST CONFIDENCE AND ARE ONLY TO BE USED IN THE COMMERCIAL INTERESTS OF CMS ELECTRACOM PTY LTD DRAWN IN mm TO AS1100 DO NOT SCALE
DRAWING: LU39871	

TITLE: FR210CS	
DRAWING: LU39871	REV: 6
SCALE 1:5	
SHEET 1 OF 2	

A3