

# Assembly, Operating & Maintenance Instructions

Remove all items from the carton. Verify all pieces before assembly

## BURO METRO CHAIR - WITH/WITHOUT ARMS

STEP 1.

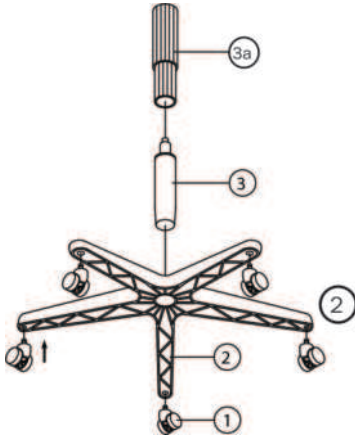

STEP 2.

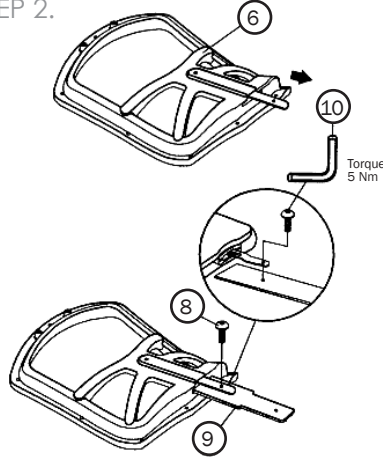

The Metro backrest post (9) may initially be tight to assemble when new.

STEP 3.

\*Arm assembly instructions for Metro Chairs purchased with arms only.

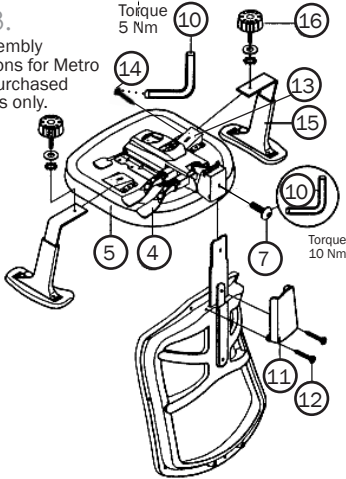

Mechanism pre-assembled to seat.



\*Line drawing of completed Metro Chair purchased with arms only.

## PART LIST

KEY	QTY	DESCRIPTION
1	5	Castors
2	1	Base
3	1	Gas Lift
3a	1	Gas Lift bellows*
* for Metro chairs with black nylon base only		
4	1	Mechanism
5	1	Seat
6	1	Backrest
7	1	Backrest Tight Bolt
8	1	Backrest Screw
9	1	Backrest Post
10	1	M5 Size Allen Wrench
11	1	Backrest Post Bellow
12	2	Backrest Post Bellow Screw
*13	2	Armrest Brackets
*14	8	Armrest Screws
*15	2	Armrest
*16	2	Arm Width Adjustment Knobs & Washers

\*Parts required for Metro Chairs purchased with arms only.

## FOAM & UPHOLSTERY SPECS\*

### FOAM

Flame Resistance: Ca117 Section A Part I & Section D Part II

### UPHOLSTERY

Flame Resistance: Ca117 Section E Class I

\*This applies only to standard Buro stock. Any customer specified upholstery may not meet these specifications.

## CARE & MAINTENANCE

### GENERAL CARE

To maintain the appearance of non-upholstered parts wipe the surface with a clean cloth dampened with a mild detergent solution. Do not remove any parts for separate cleaning. Do not saturate the fabric or interior with water or other cleaning liquids. Do not shampoo clean.

Do not clean with hot water extraction machine.

Do not clean with onsite drycleaning machine.

Protect from direct sunlight, heat and weather.

### FABRIC UPHOLSTERY CARE

Wipe with a clean cloth dampened with a mild upholstery detergent solution.

A soft bristle brush may be used to remove ingrained soil.

Spot clean as above. Treat spills and stains as soon as possible.

Persistent stains may require treatment by a professional cleaner.

May be cleaned with dry powder cleaners.

Allow to dry thoroughly before reuse.

## OPERATING INSTRUCTIONS!

### RECOMMENDED SEATING POSITION & ADJUSTMENTS:

- Sit in the chair, adjust the seat tilt so that it is approximately horizontal or inclined slightly forward, to allow an angle greater than 90° at the knees and the hips.
- Adjust the seat height so that your feet are resting flat on the floor. For good circulation, your lower legs should form a 90° angle with the floor, with your feet taking the weight of your legs.
- Adjust the backrest tilt function accordingly, to give your back firm support while sitting upright.
- Adjust the height of the backrest to give support to the lumbar region of your back.
- Your forearms should be close to horizontal as possible when working at a desk.

### BACKREST INSTRUCTIONS:

The backrest (6) height adjustment operation, may initially be tight to raise and lower when new. This is normal and a standard factory tolerance setting.



To achieve smooth operation raise and lower the backrest multiple times before using the chair.

### MECHANISM OPERATING INSTRUCTIONS:

**IMPORTANT NOTE:** Do not operate the mechanism levers unless properly seated in the chair.

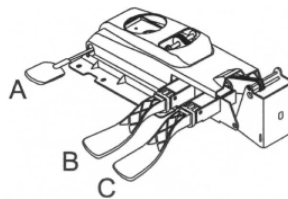

A Pneumatic seat height adjustment

B **Seat angle adjustment:** Seat angle adjusts independently with a single lever

C **Backrest angle adjustment:** Back angle adjusts independently with a single lever

## PREVENTATIVE MAINTENANCE & WARNING!

- Use this product only for seating one person at a time.
- Do not use this chair as a step stool/ladder.
- Do not sit on any part of the chair except the seat.
- Do not use this chair on uneven floor surfaces.
- Do not interfere with the operating of the gas lift.
- Do not use chair unless all bolts, screws and knobs are tight. At least every six months check all bolts, screws and knobs to ensure they are tight.
- If any parts are missing, broken, damaged or worn do not use the product until repairs are made using factory authorised parts.
- Dispose of packaging properly.
- Plastic bag is not a toy.
- Do not use plastic bag as a head covering as it may cause suffocation.
- Failure to follow these warnings could result in serious injury.