

Assembly, Operating & Maintenance Instructions

Attention: Please remove all items from the carton, and verify all pieces before assembly.

Buro Metro II 24/7 Chair - with Seat Slide Buro Metro II 24/7 HB Chair - with Seat Slide

Step 1

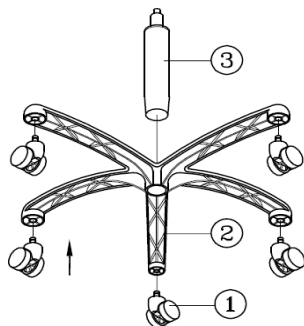

Step 2

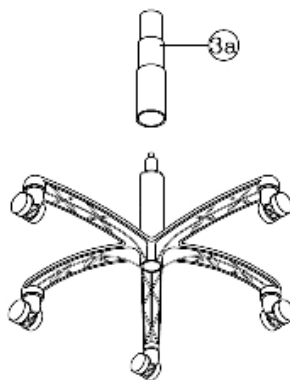

Step 3

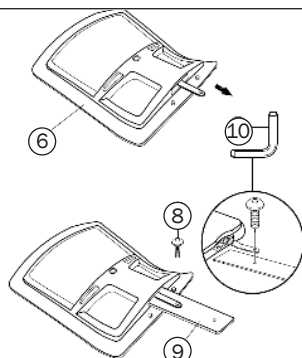

Ensure the word 'Outward' on the backrest post (9) is facing outward and the text is the right way up. Please note the backrest post may initially be tight to assemble.

Step 4

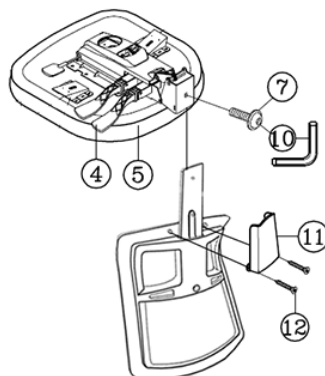

Step 5

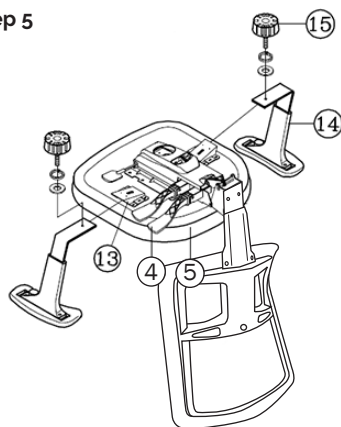

BACKREST INSTRUCTIONS:

The backrest (6) height adjustment operation, may initially be tight to raise and lower when new. This is normal and a standard factory tolerance setting.

To achieve smooth operation raise and lower the backrest multiple times before using the chair.

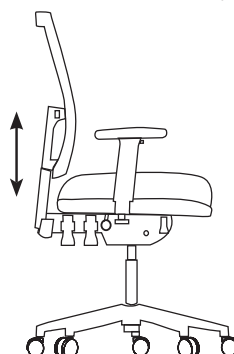

MECHANISM OPERATING INSTRUCTIONS

IMPORTANT NOTE: Do not operate the mechanism levers unless properly seated in the chair.

- A Pneumatic seat height adjustment.
- B **Seat angle adjustment:** Seat angle adjusts independently with a single lever.
- C **Backrest angle adjustment:** Back angle adjusts independently with a single lever.
- D **Sliding seat:** This provides seat depth adjustment for people with longer legs.

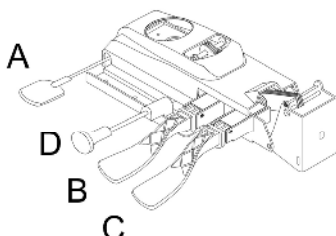

Parts List

| KEY | QTY | DESCRIPTION |
|-----|-----|--|
| 1 | 5 | Castors |
| 2 | 1 | Base |
| 3 | 1 | Gas lift |
| 3a | 1 | Gas lift bellow |
| 4 | 1 | Mechanism |
| 5 | 1 | Seat |
| 6 | 1 | Backrest |
| 7 | 1 | Backrest tight bolt |
| 8 | 1 | Backrest screw |
| 9 | 1 | Backrest post |
| 10 | 1 | M5 size allen wrench |
| 11 | 1 | Backrest post bellow |
| 12 | 1 | Backrest post screw |
| 13 | 2 | Armrest plate |
| 14* | 2 | Armrest |
| 15* | 8 | Armrest width adjustment knob & washer |

* With Arms Model only.

Care & Maintenance

GENERAL CARE

- To maintain the appearance of non-upholstered parts wipe the surface with a clean cloth dampened with a mild detergent solution.
- Do not remove any parts for separate cleaning.
- Do not saturate the fabric or interior with water or other cleaning liquids.
- Do not shampoo clean.
- Do not clean with hot water extraction machine.
- Do not clean with onsite drycleaning machine.
- Protect from direct sunlight, heat and weather.

FABRIC UPHOLSTERY CARE

- Wipe with a clean cloth dampened with a mild upholstery detergent solution.
- A soft bristle brush may be used to remove ingrained soil.
- Spot clean as above.
- Treat spills and stains as soon as possible.
- Persistent stains may require treatment by a professional cleaner.
- May be cleaned with dry powder cleaners.
- Allow to dry thoroughly before reuse.

Upholstery & Foam Specs*

FOAM

Flame Resistant: Ca117 Section A Part I & Section D Part II

UPHOLSTERY: FABRIC

Flame Resistance: Ca117 Section E Class I

*This applies only to standard Buro Seating stock. Any customer specified upholstery may not meet these specifications.

Preventative Maintenance & Warning!

- If any parts are missing, broken, damaged or worn do not use the product until repairs are made using factory authorised parts.
- Dispose of packaging properly.
- Plastic bag is not a toy.
- Do not use plastic bag as a head covering as it may cause suffocation.
- Failure to follow these warnings could result in serious injury.
- Use this product only for seating one person at a time.
- Do not use this chair as a step stool/ladder.
- Do not sit on any part of the chair except the seat.
- Do not use this chair on uneven floor surfaces.
- Do not interfere with the operating of the gas lift.
- Do not use chair unless all bolts, screws and knobs are tight.
- At least every six months check all bolts, screws and knobs to ensure they are tight.