

Shell Four Seater Beam Assembly

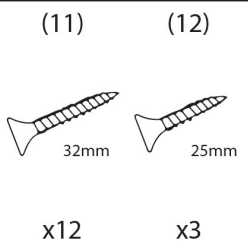

Step One

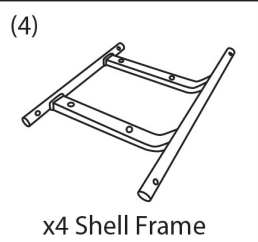
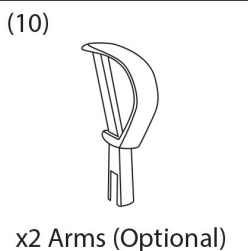
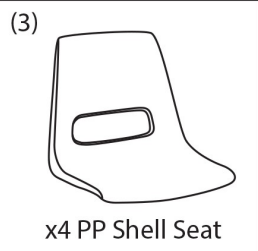
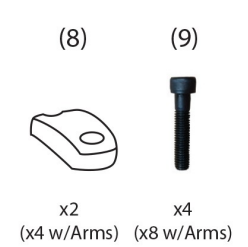
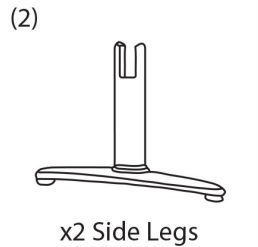
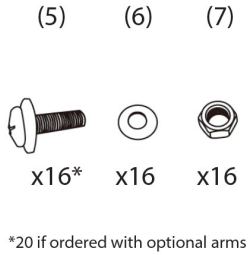
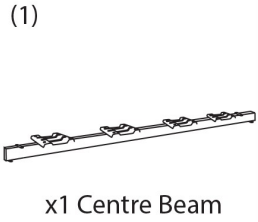
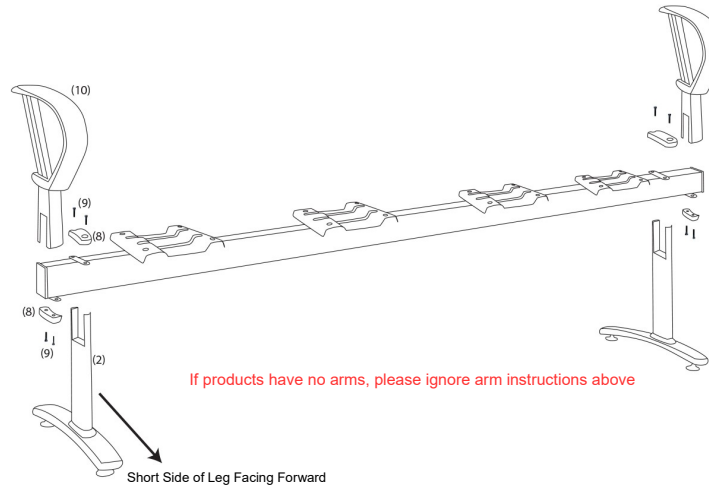

Affix Side Legs (2) to the Centre Beam (1) and use the provided screws (9) to secure (8) to the welded bracket. If your Shell Beam Seater was ordered with Optional Arms, please affix (10) to the welded brackets on the edge of the Centre Beam (1)

Step Two

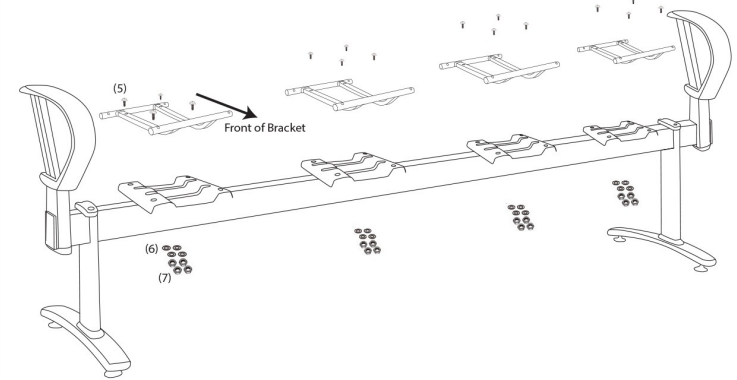

Affix the four provided Shell Frames (4) to the Centre Beam (1) using the provided items (5, 6, 7). Please ensure that the elevated section of the Shell Frame is facing forward when affixing to the brackets.

Step Three

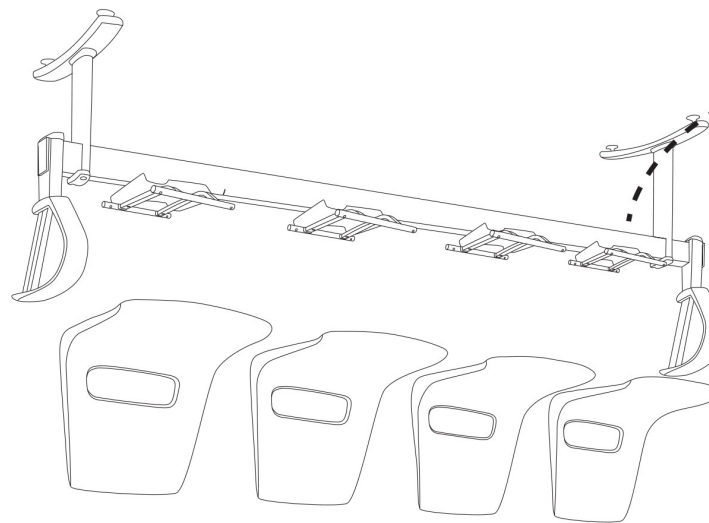

Turn beam assembly upside down and hold PP Shell Seat (3) in position for attachment. Please follow Step Four for instructions in affixing the seat to the bracket.

Step Four

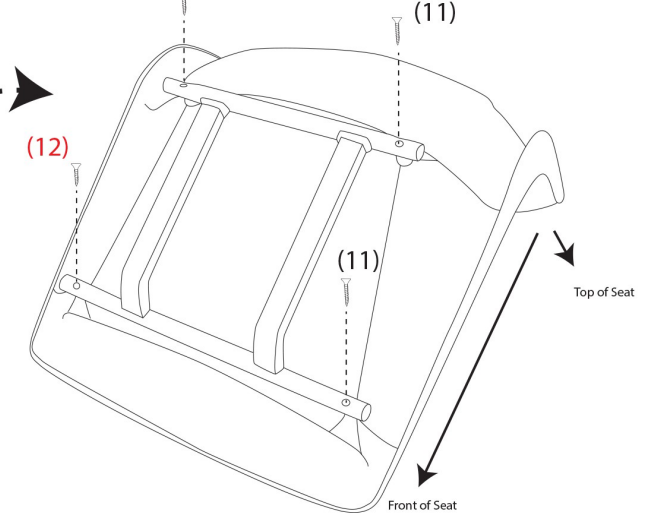

When affixing Shell Frame (4) to PP Shell Seat (3). Please be mindful of the screw locations as shown in the above diagram. The bottom left screw (12) is shorter than the other screws (11)