

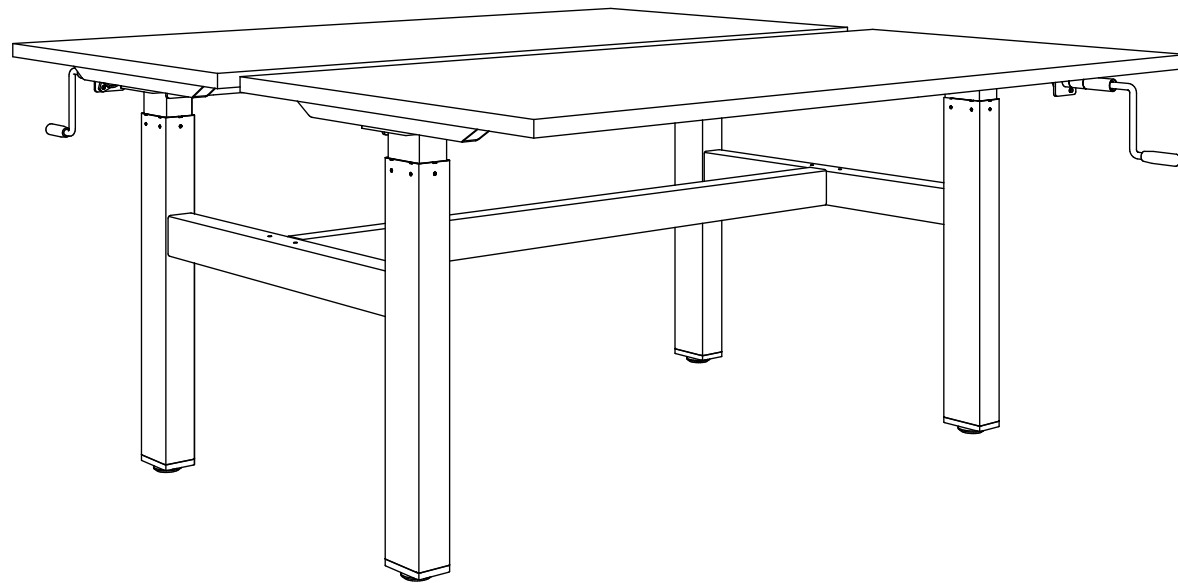

freeway

Agile

Installation Guide - Winder 2 Column



Parts:

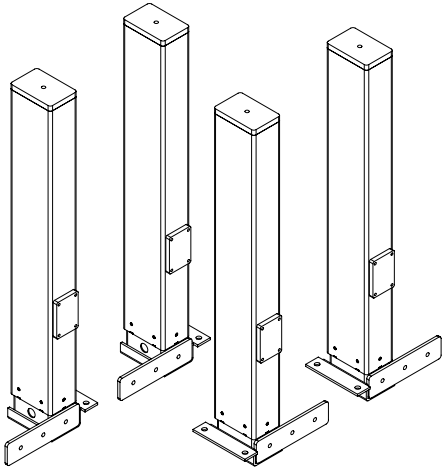

2 x L&R Leg Pair

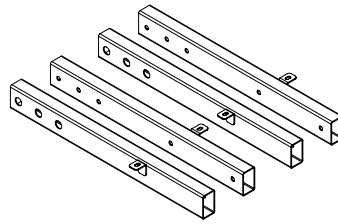

2 x L&R Leg Rail Pair

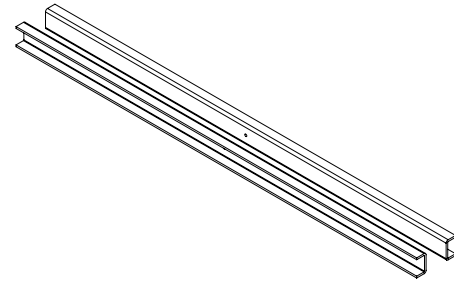

2 x Cross Rail

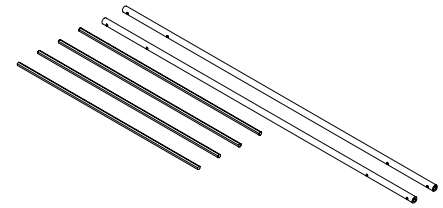

2 x Drive Shaft

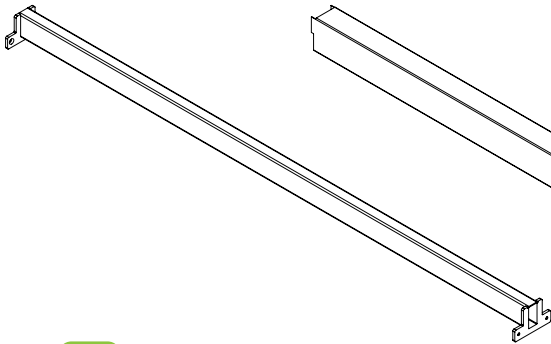

1 x Cross Beam

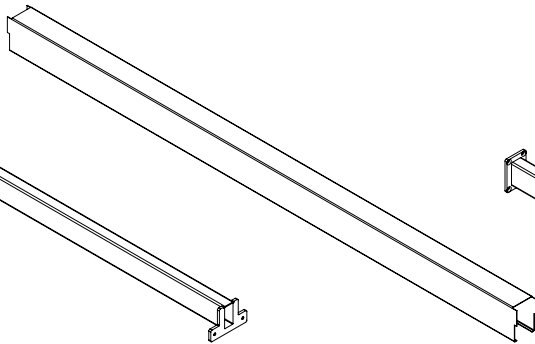

1 x Cross Beam Cover

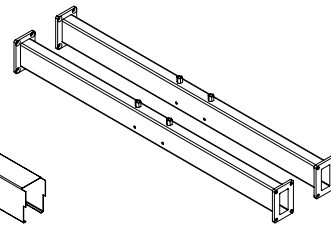

2 x Leg Beam

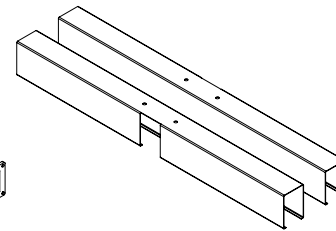

2 x Leg Beam Cover

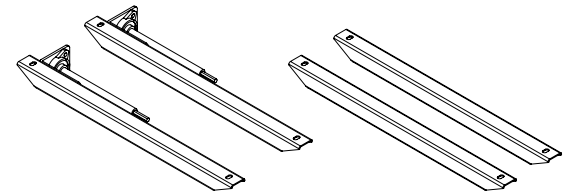

2 x L&R Support Bar Pair

Parts:

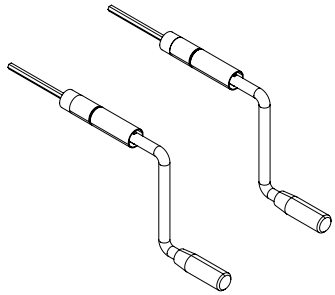

2 x Winder

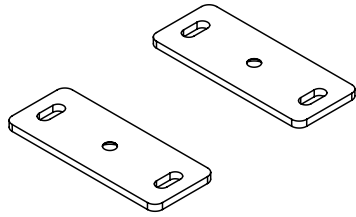

2 x Screen Bracket

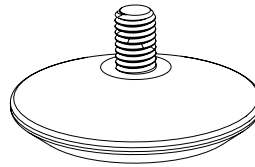

4 x Levelling Foot

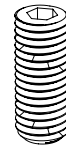

8 x M10x25



20 x M8x10



12 x ST5.0x22

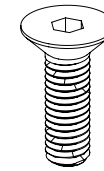

2 x M6x20



4 x M5x15

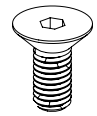

20 x M5x12

Step 1



12 x M8x10

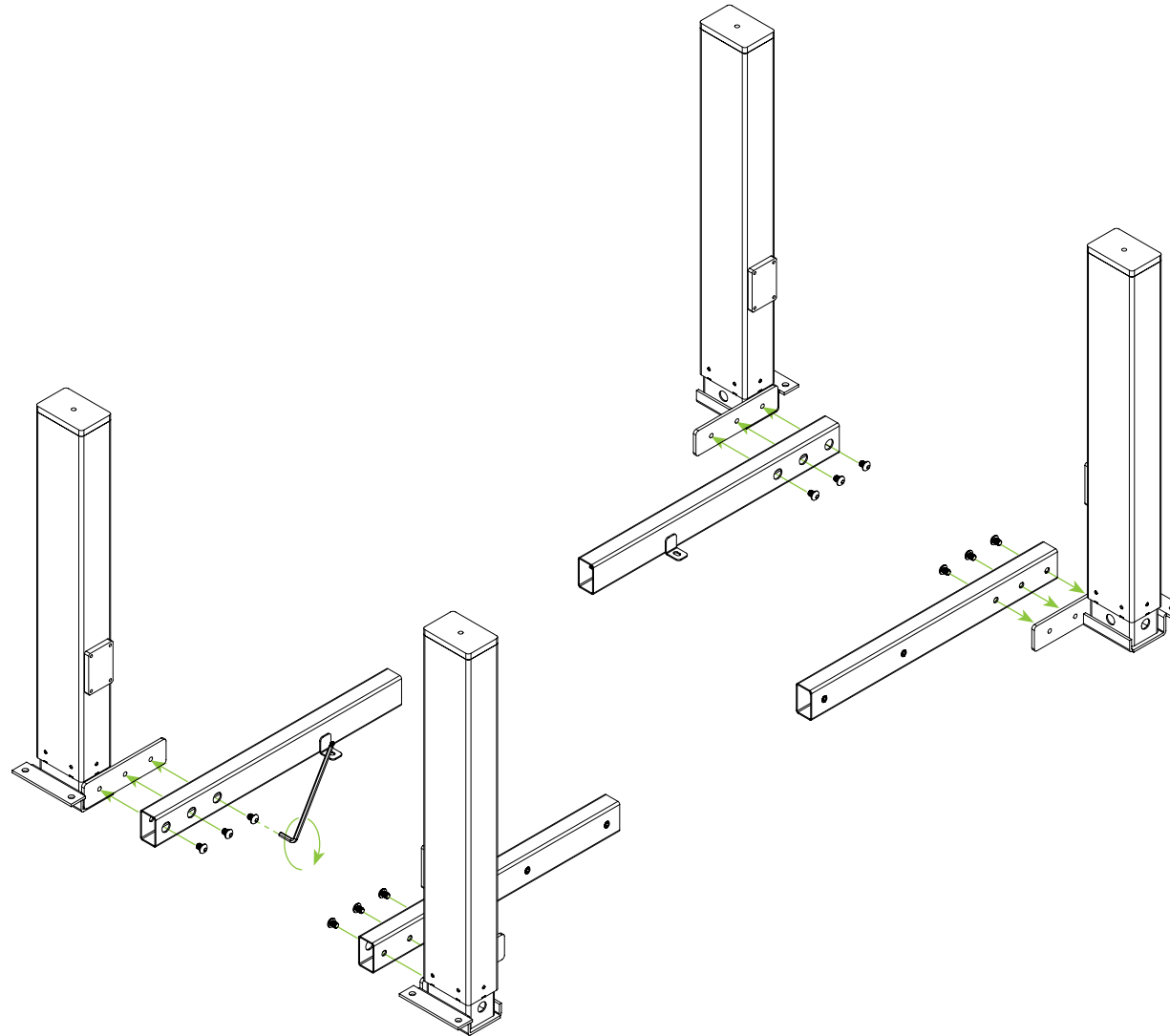

Step 2



8 x M6x10

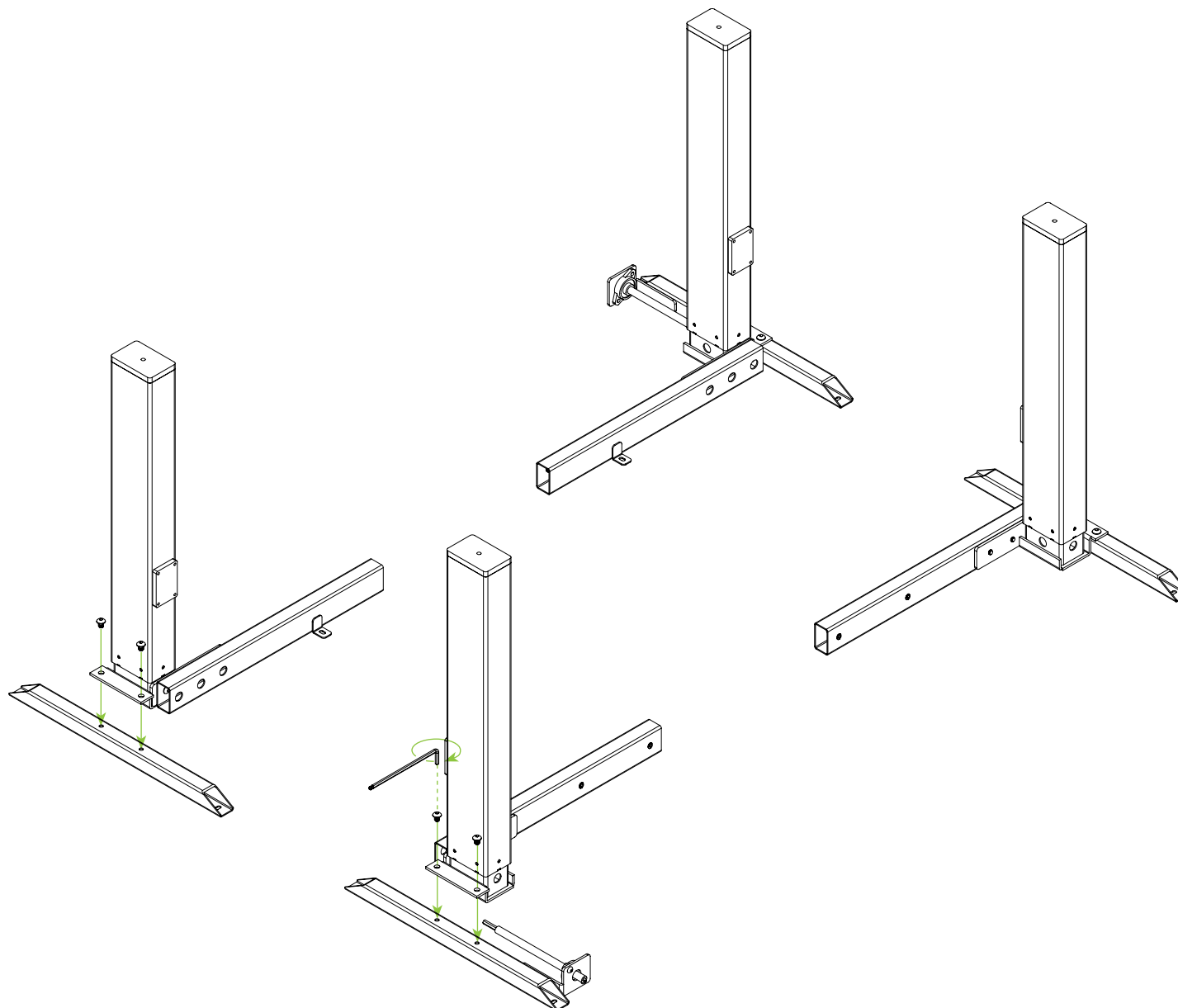

Step 3

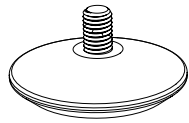

4 x Levelling Foot

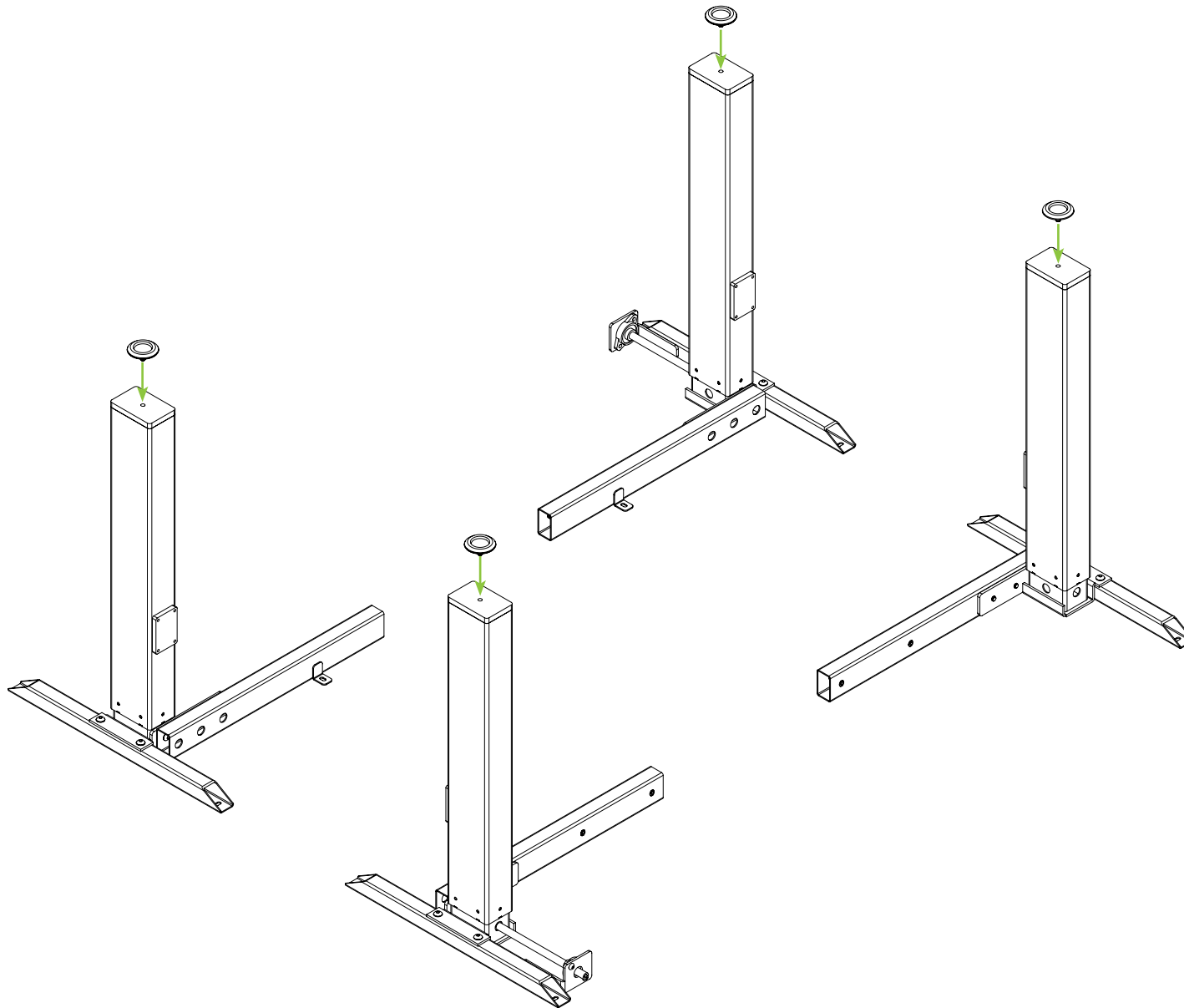

Step 4

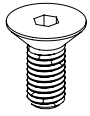

16 x M5x12

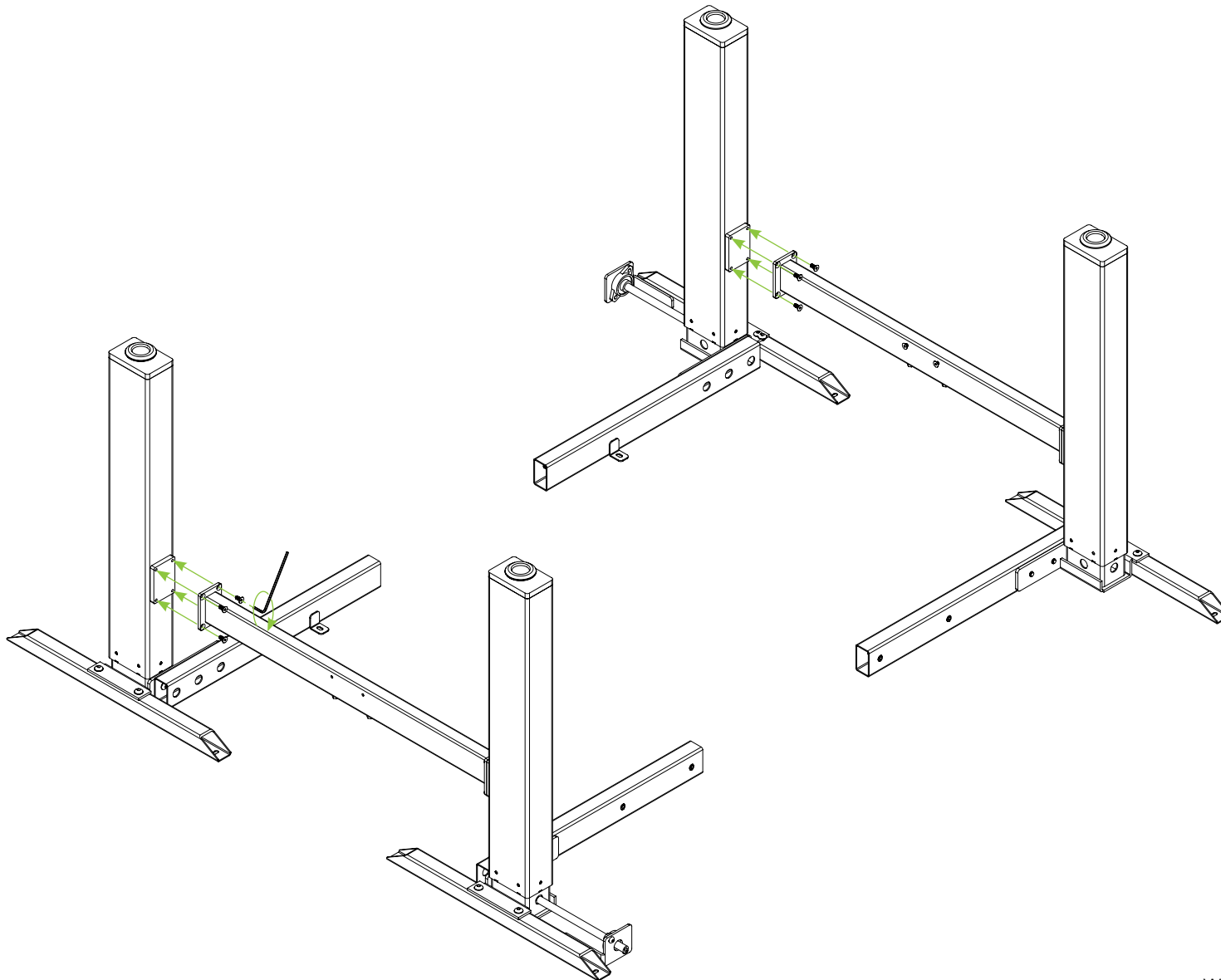

Step 5

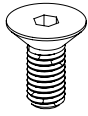

4 x M5x12

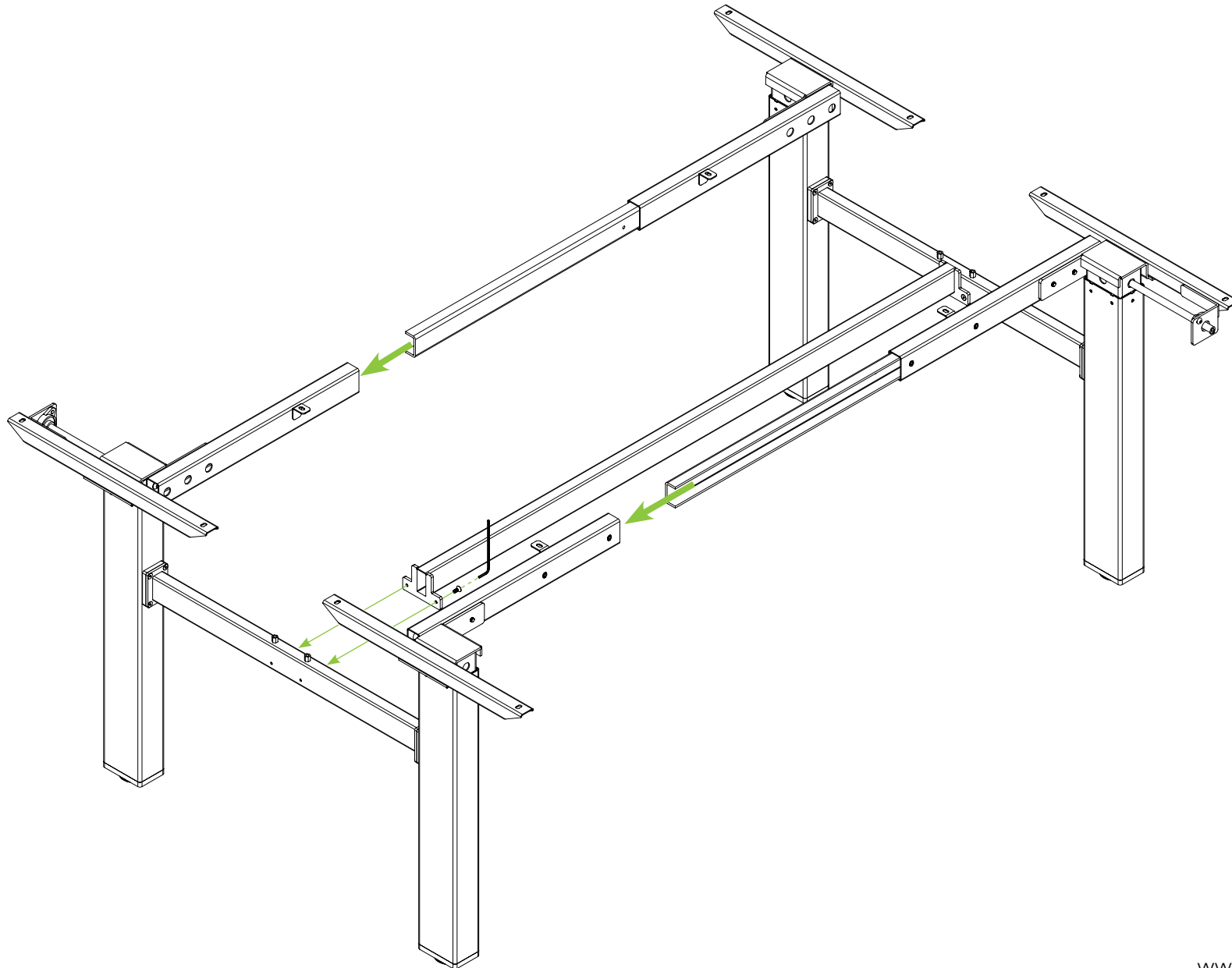

Step 6



8 x M10x25

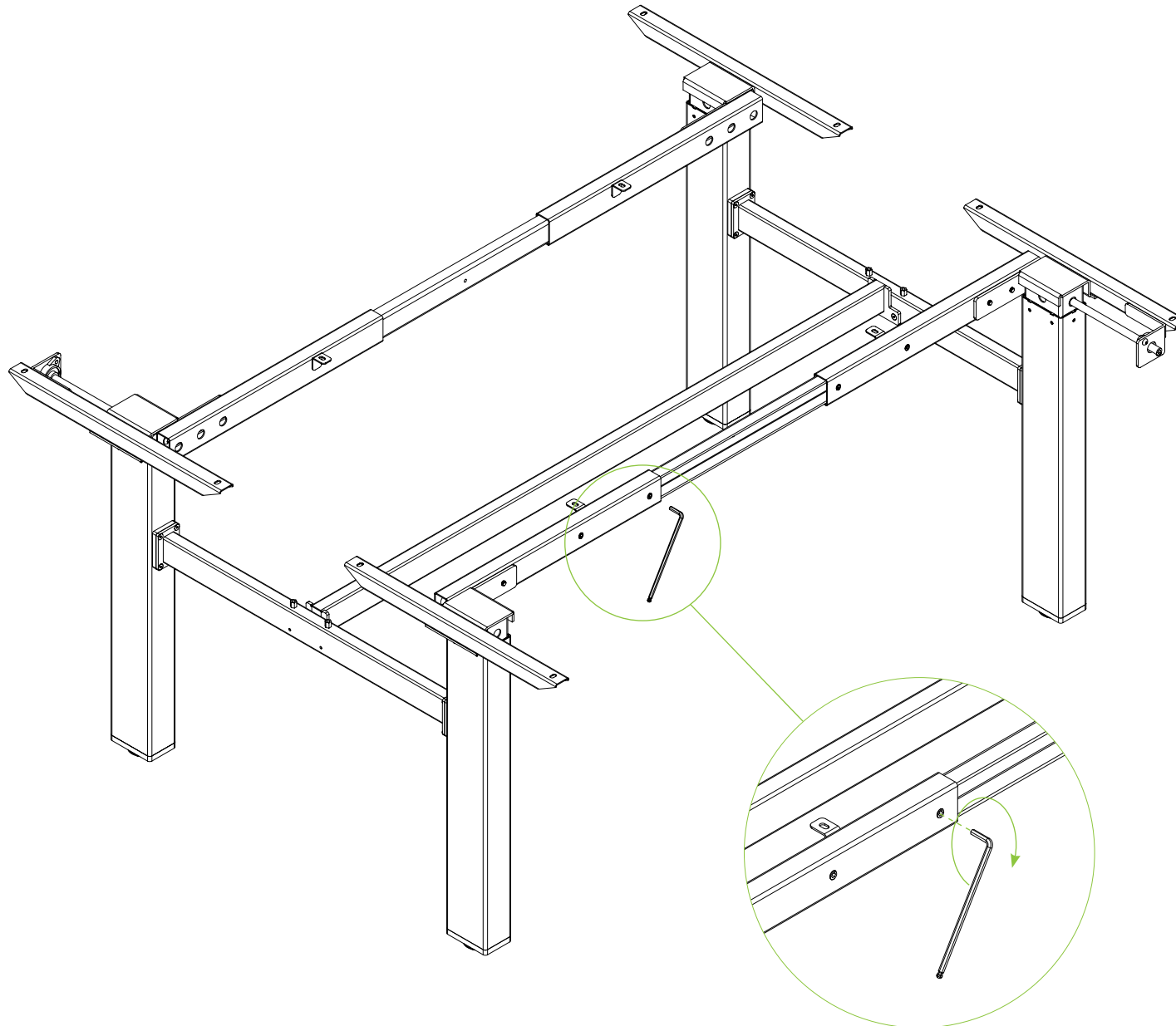

Step 7

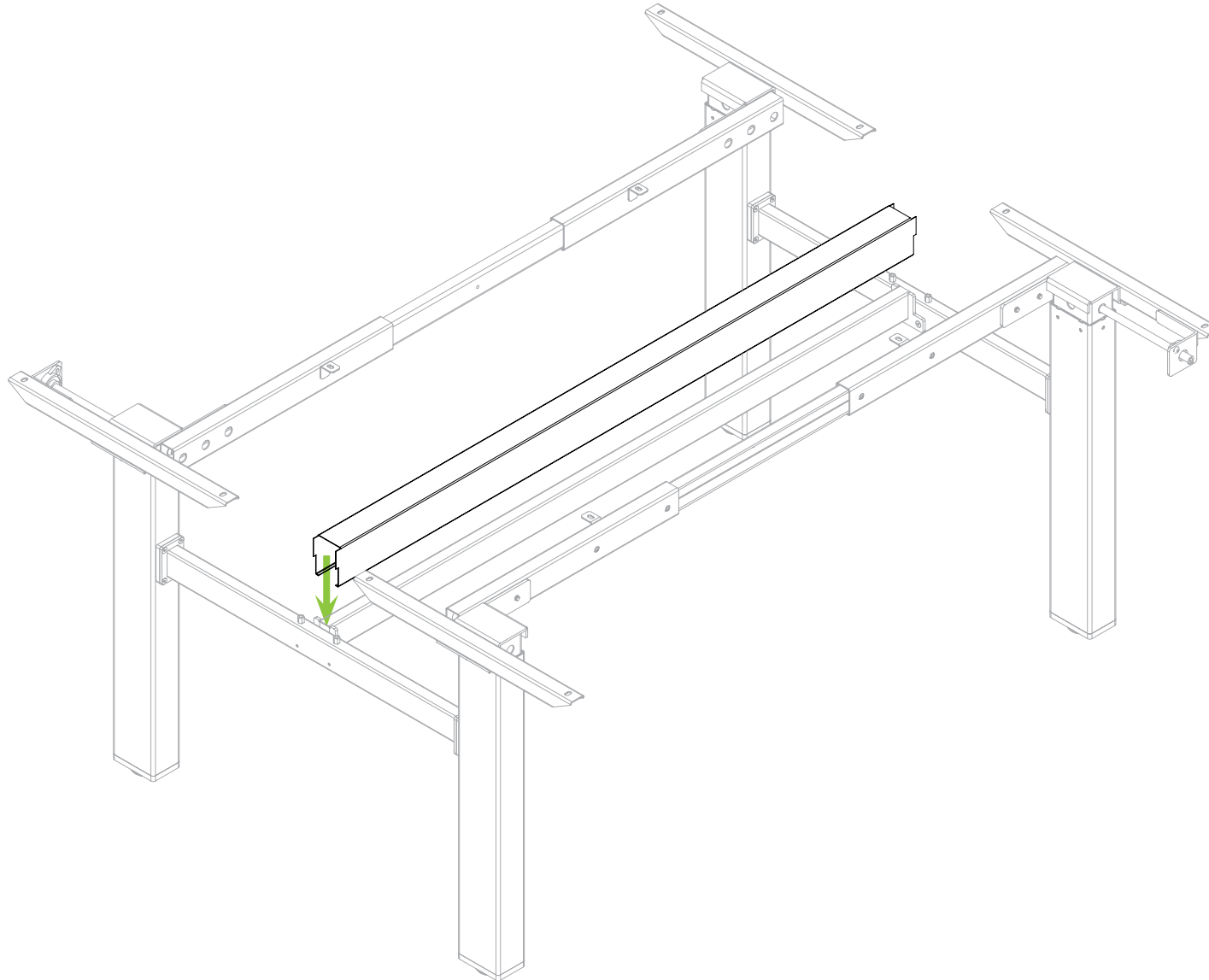

Step 8

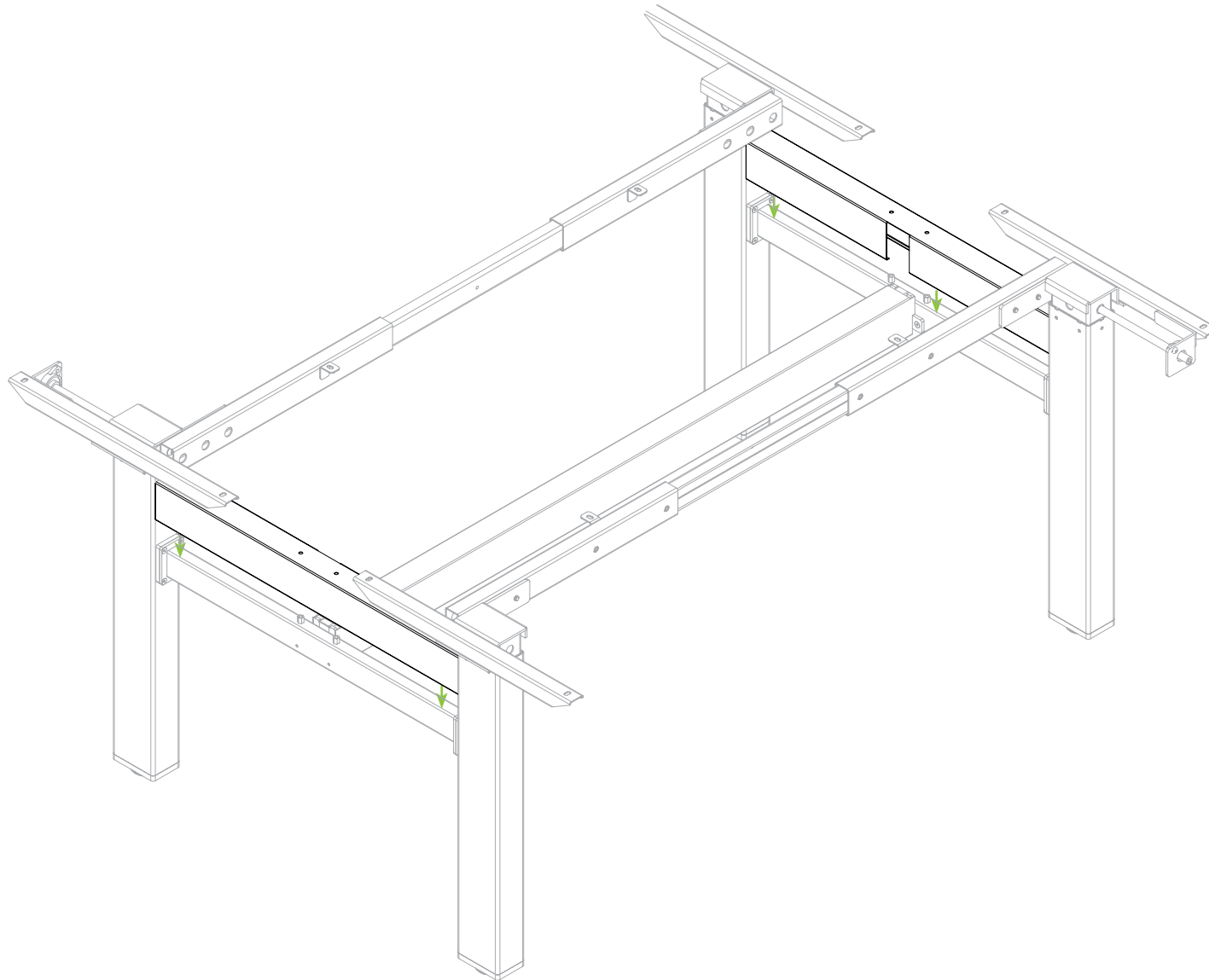

Step 9

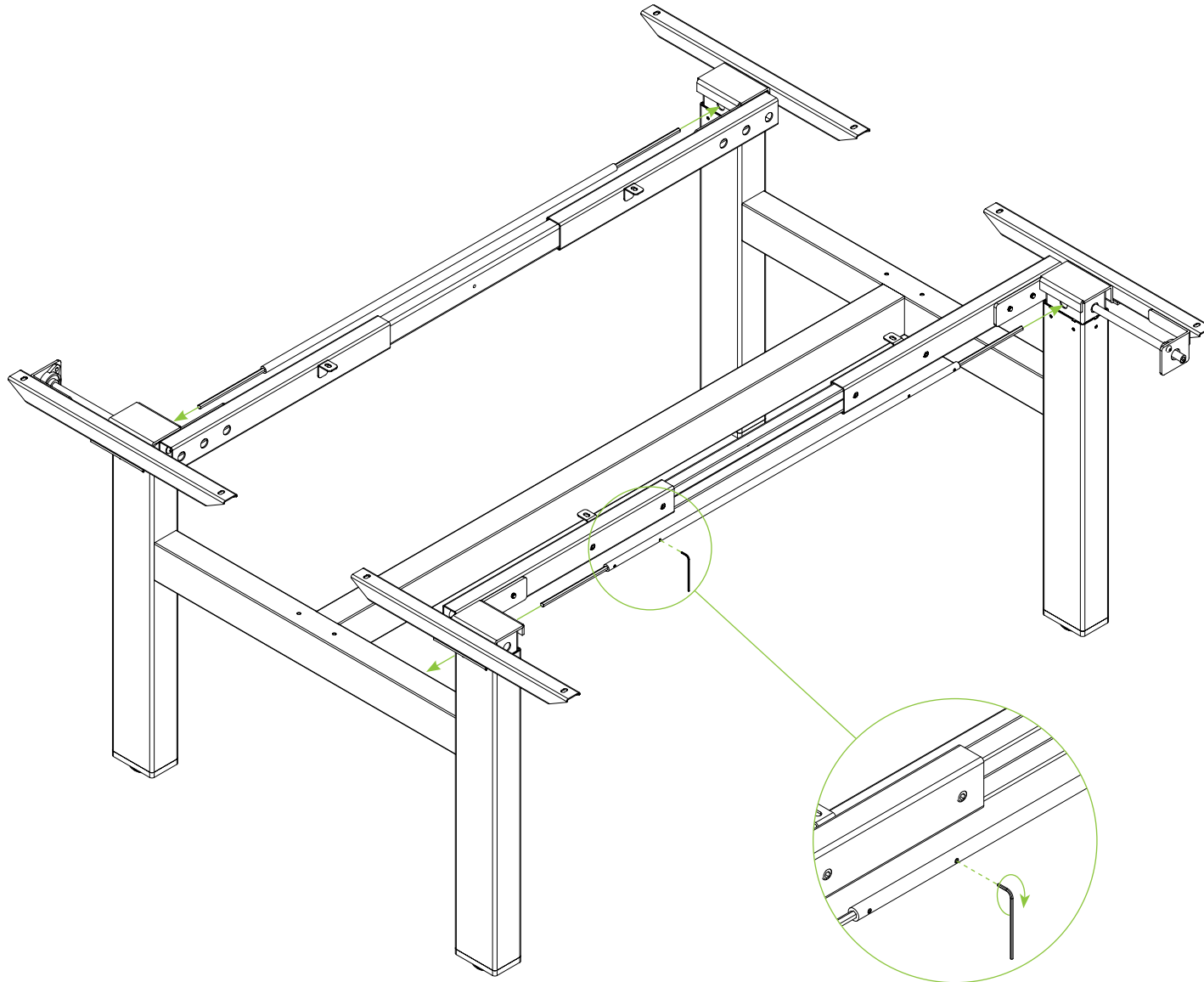

Step 10

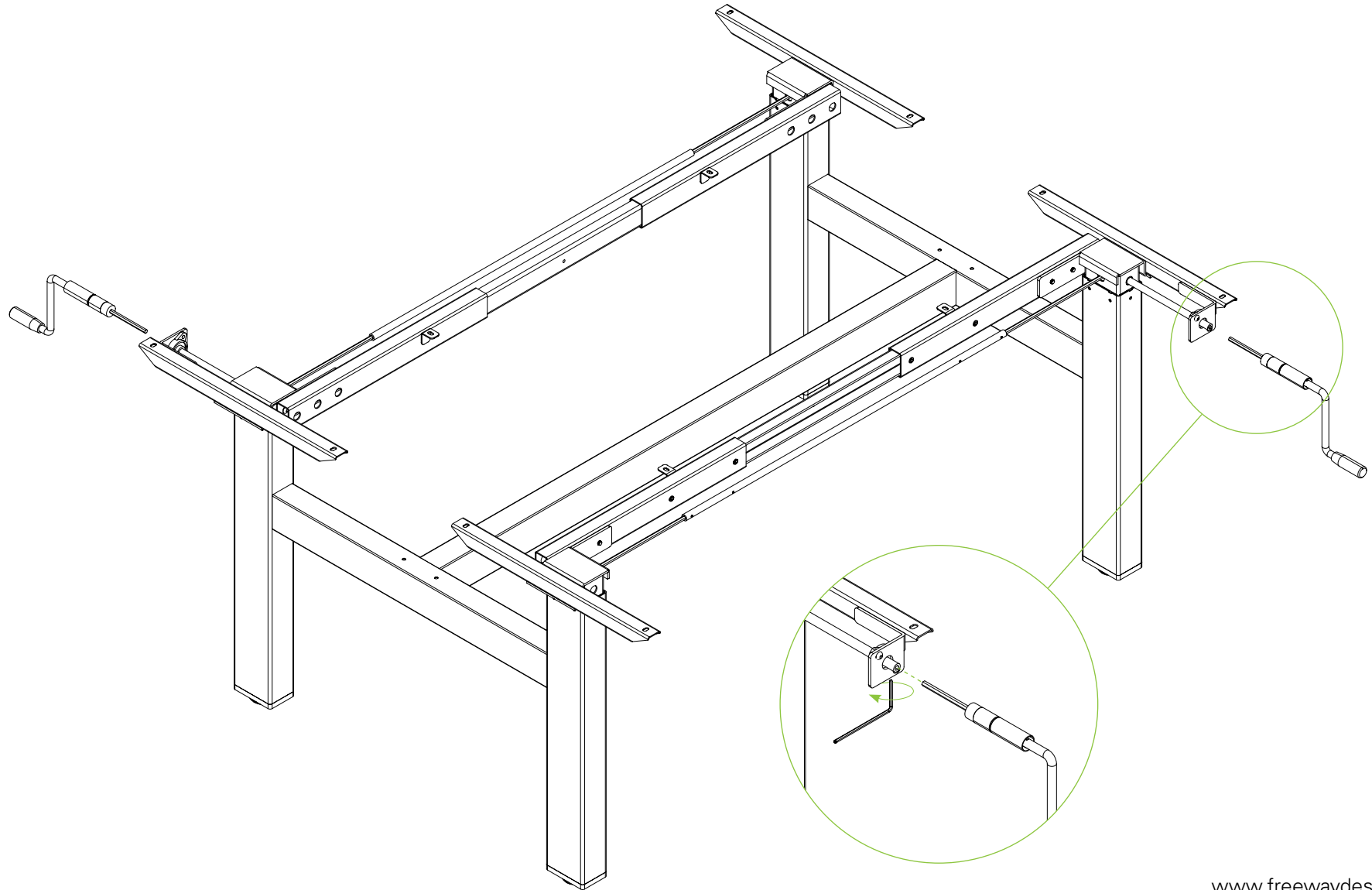

Step 11

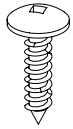

12 x ST5_0x22

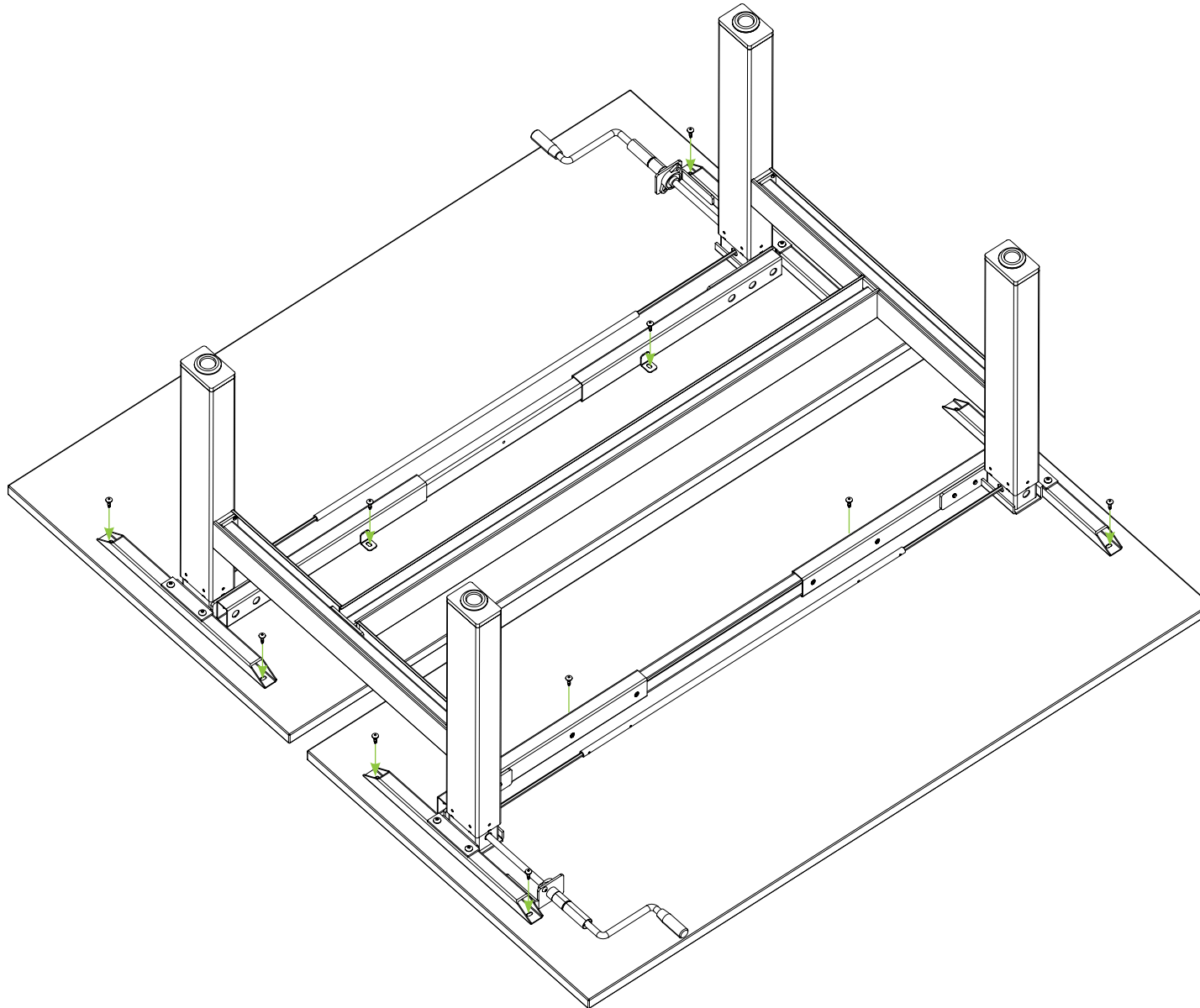

Step 12

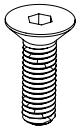

2 x M6x20

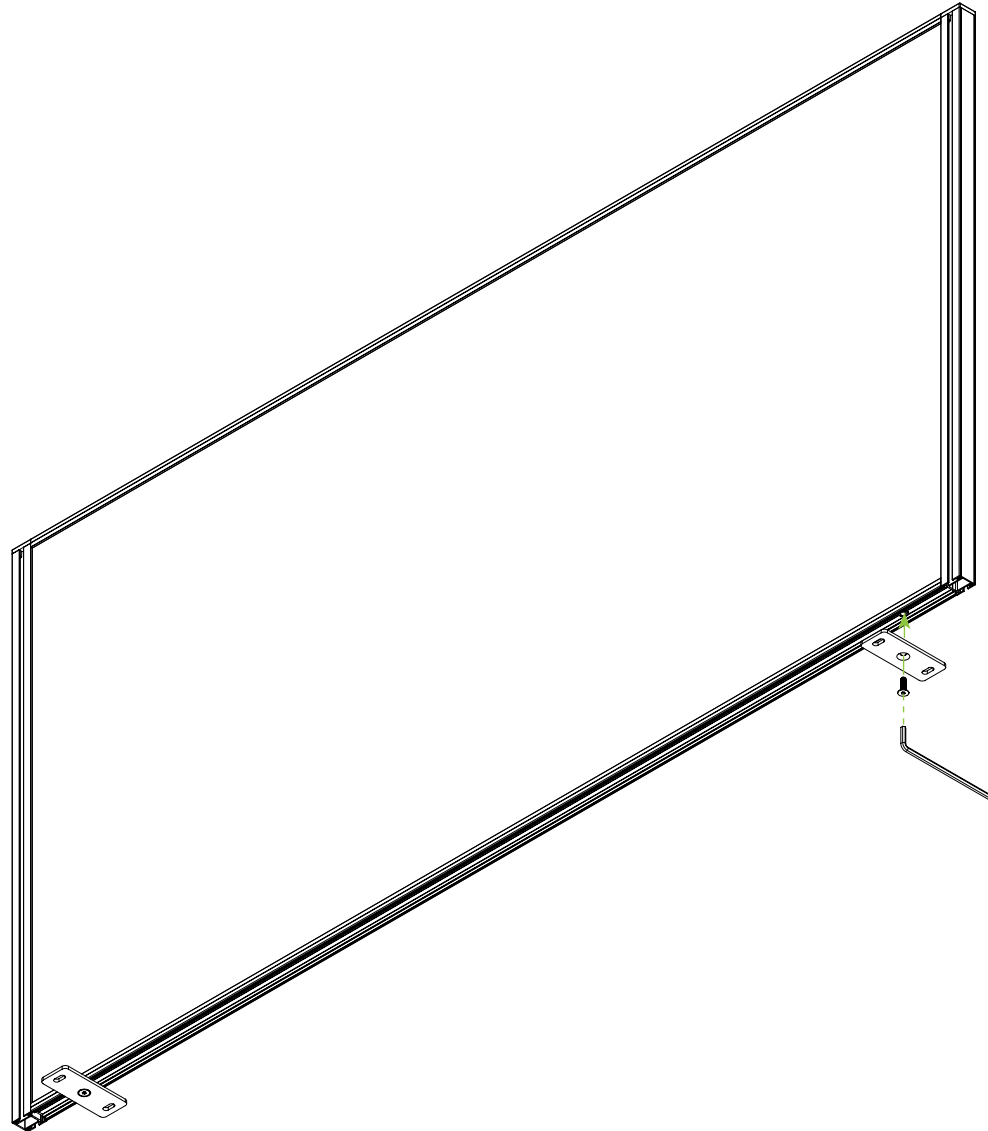

Step 13

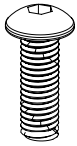

4 x M5x15

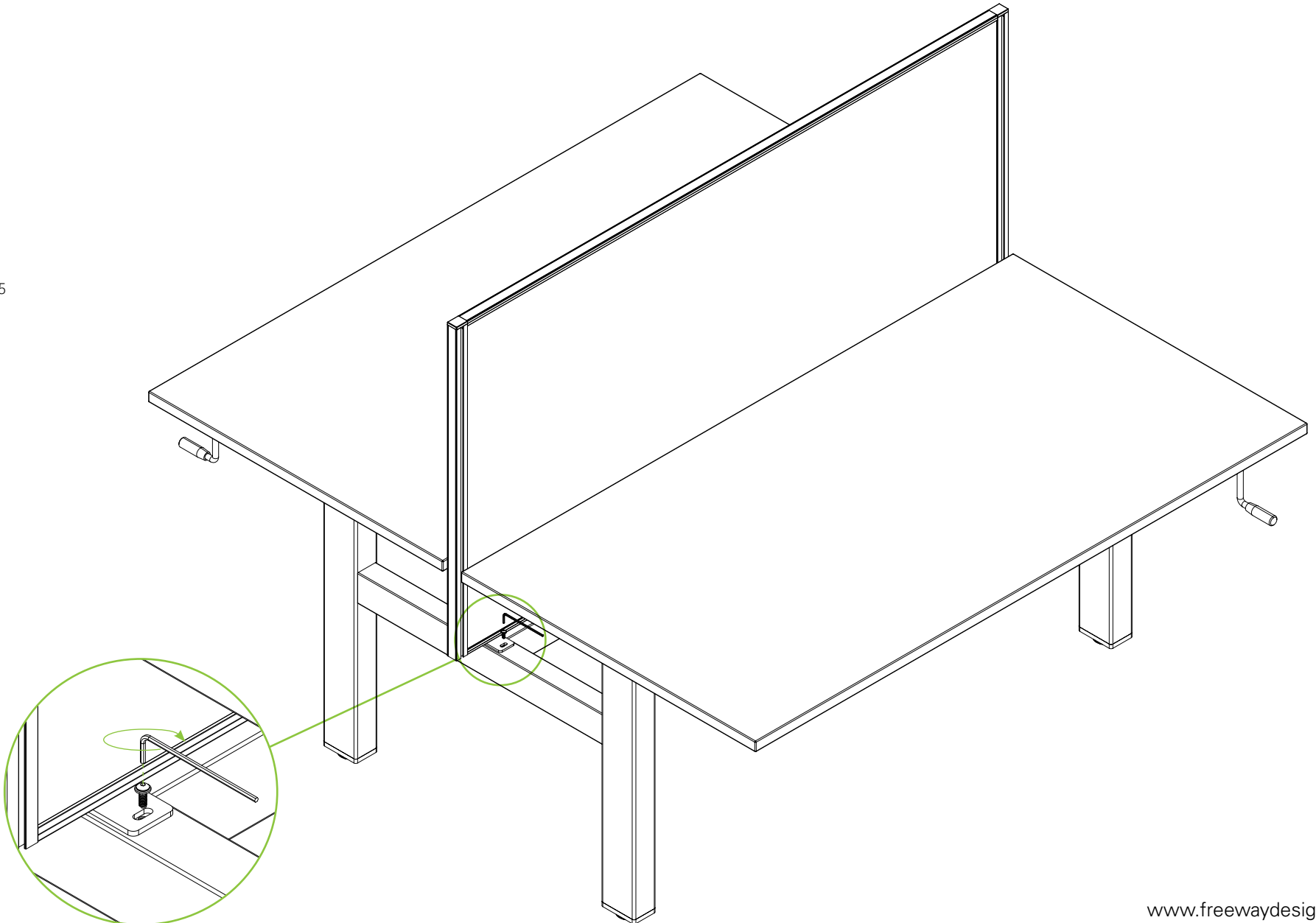

Step 14

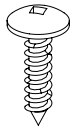

8 x ST5.0x22

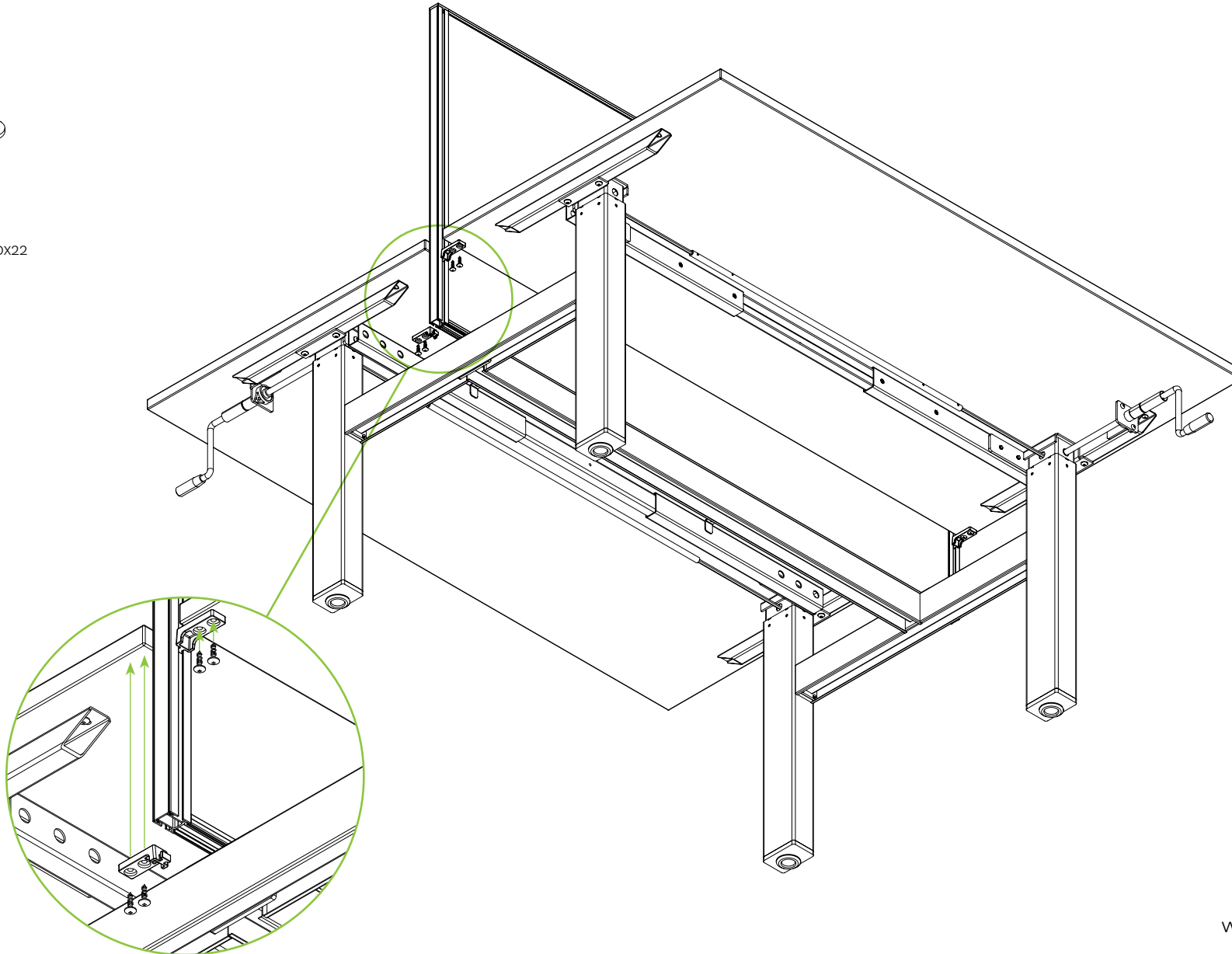

Completed

