



freeway

# Agile

Installation Guide - Winder 2 Column

---

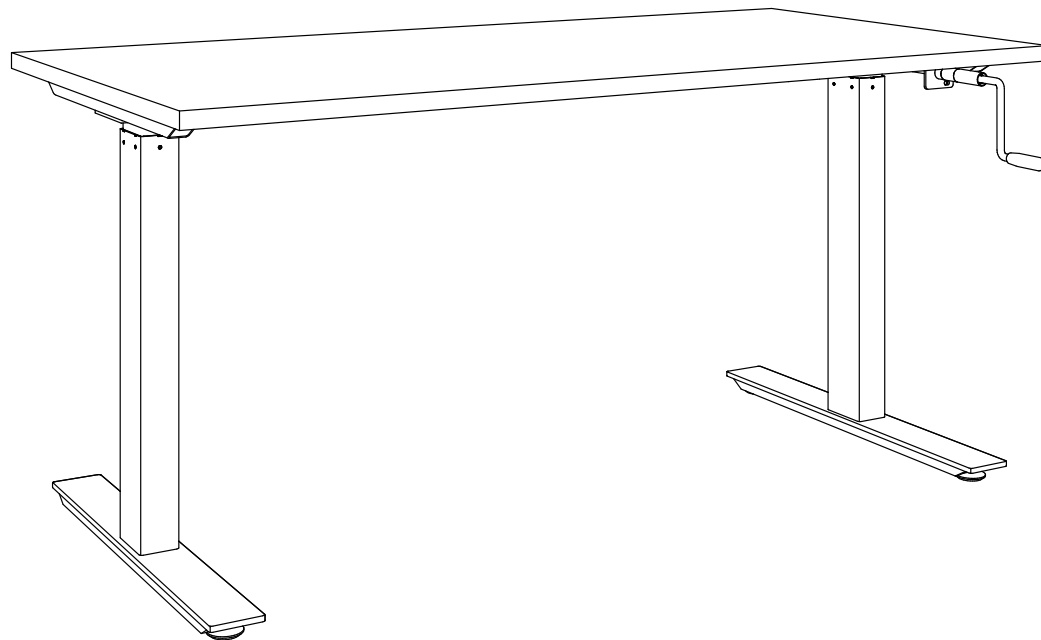

### Parts:

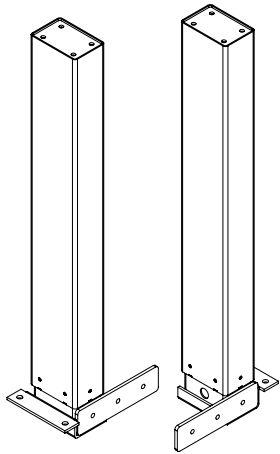

1 x Left & Right Leg Pair

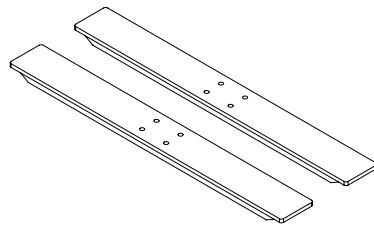

2 x Foot

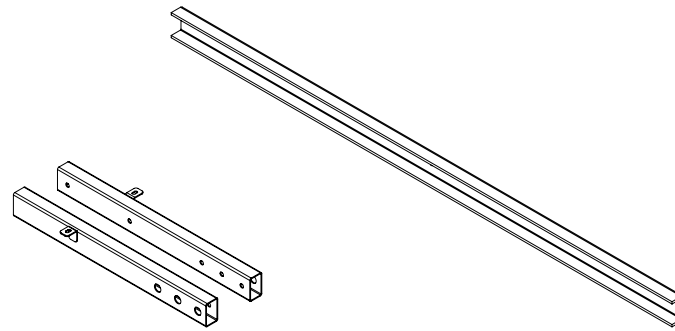

2 x Leg Rail

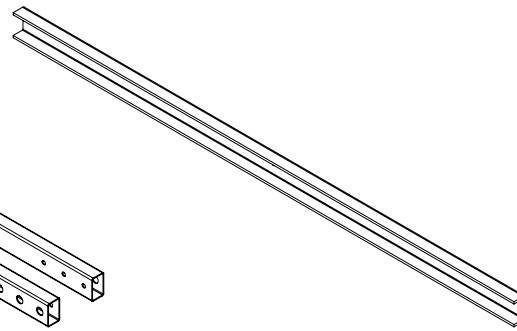

1 x Cross Rail

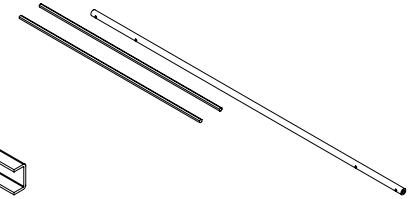

1 x Drive Shaft

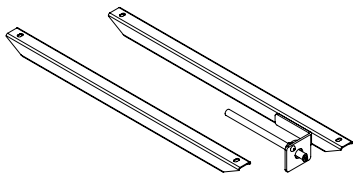

1 x L&R Support Bar Pair

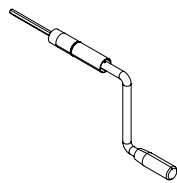

1 x Winder

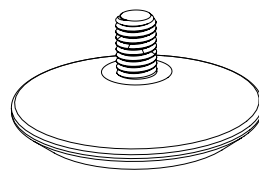

4 x Levelling Foot

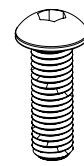

8 x M8x25



10 x M8x10

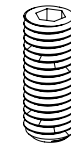

4 x M10x25

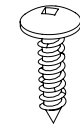

6 x ST5.0x22

### Step 1



6 x M8x10

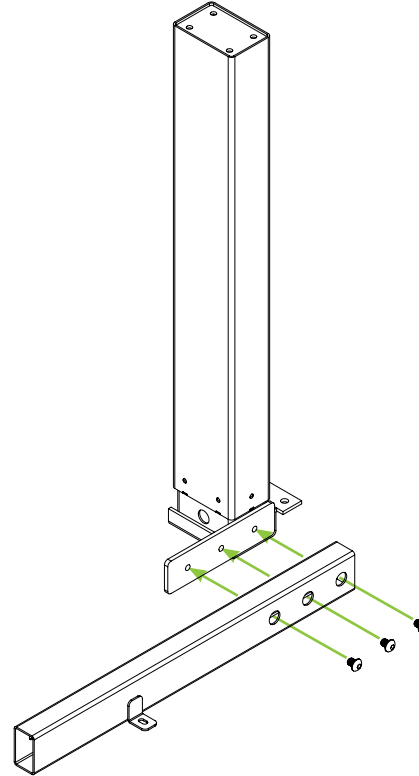
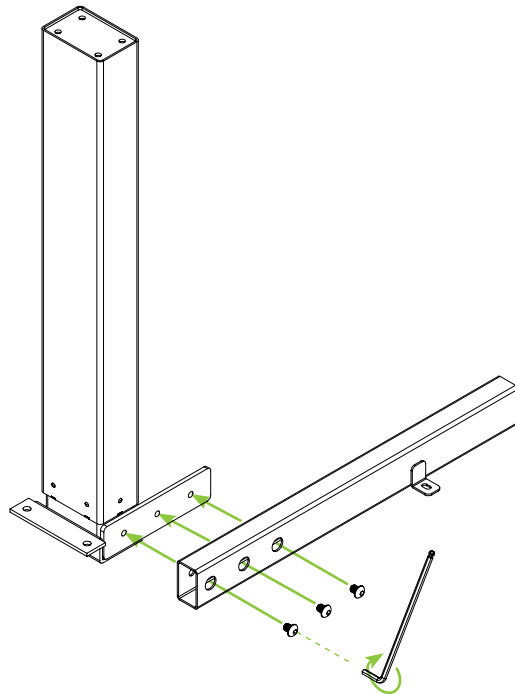

### Step 2



4 x M8x10

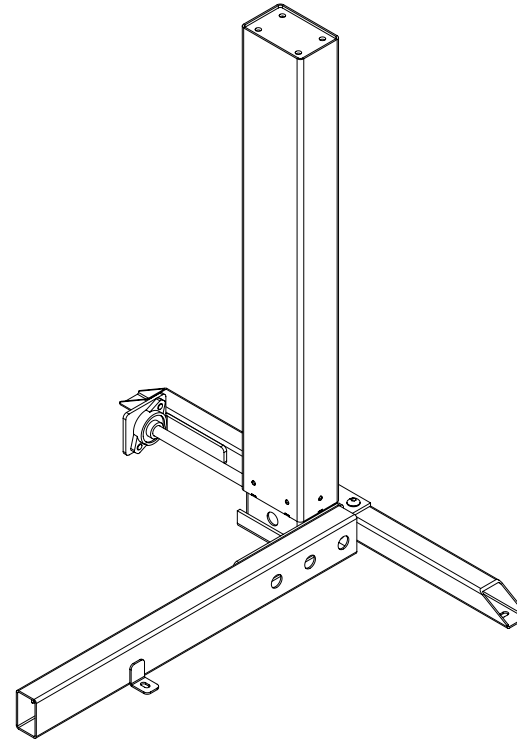
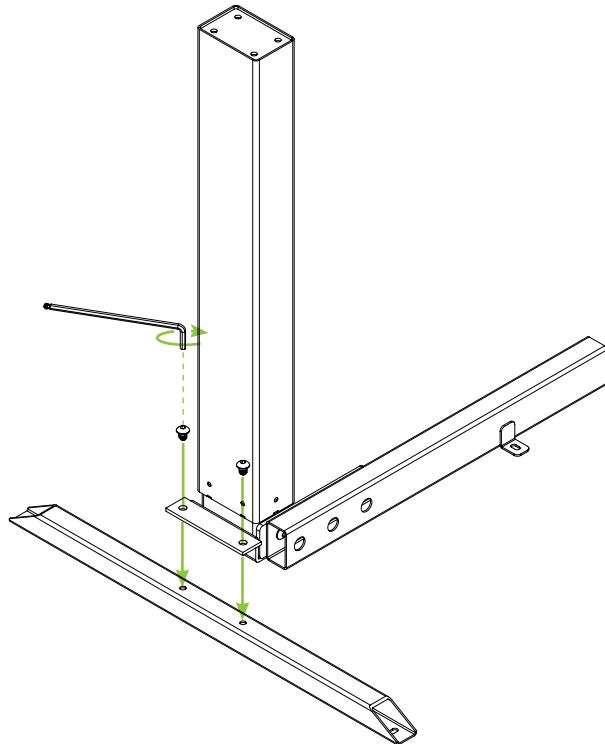

### Step 3

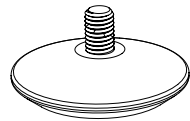

4 x Levelling Foot

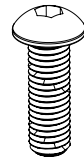
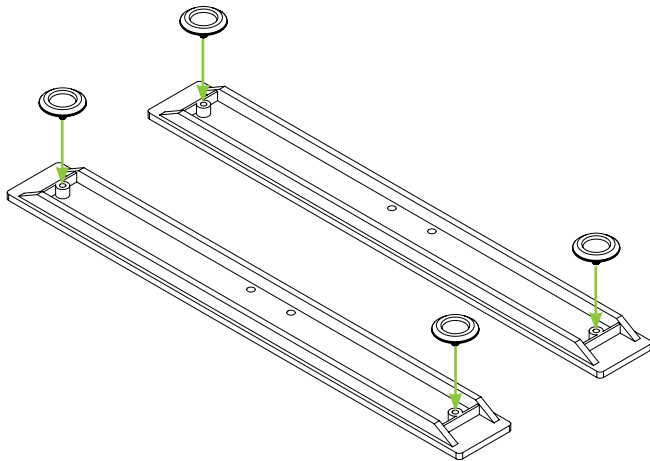

8 x M8x25

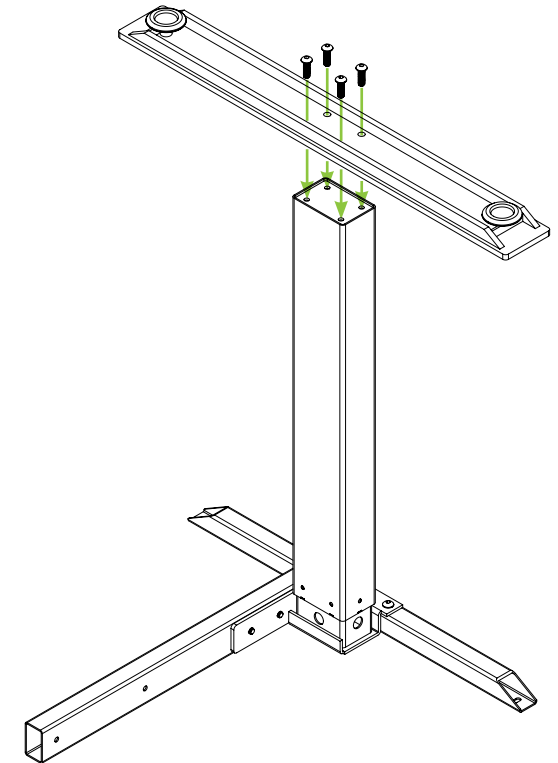
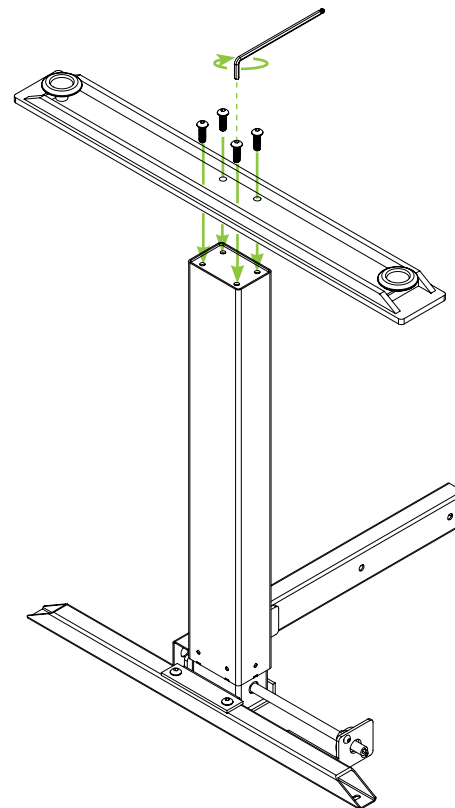

### Step 4

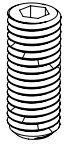

4 x M10x25

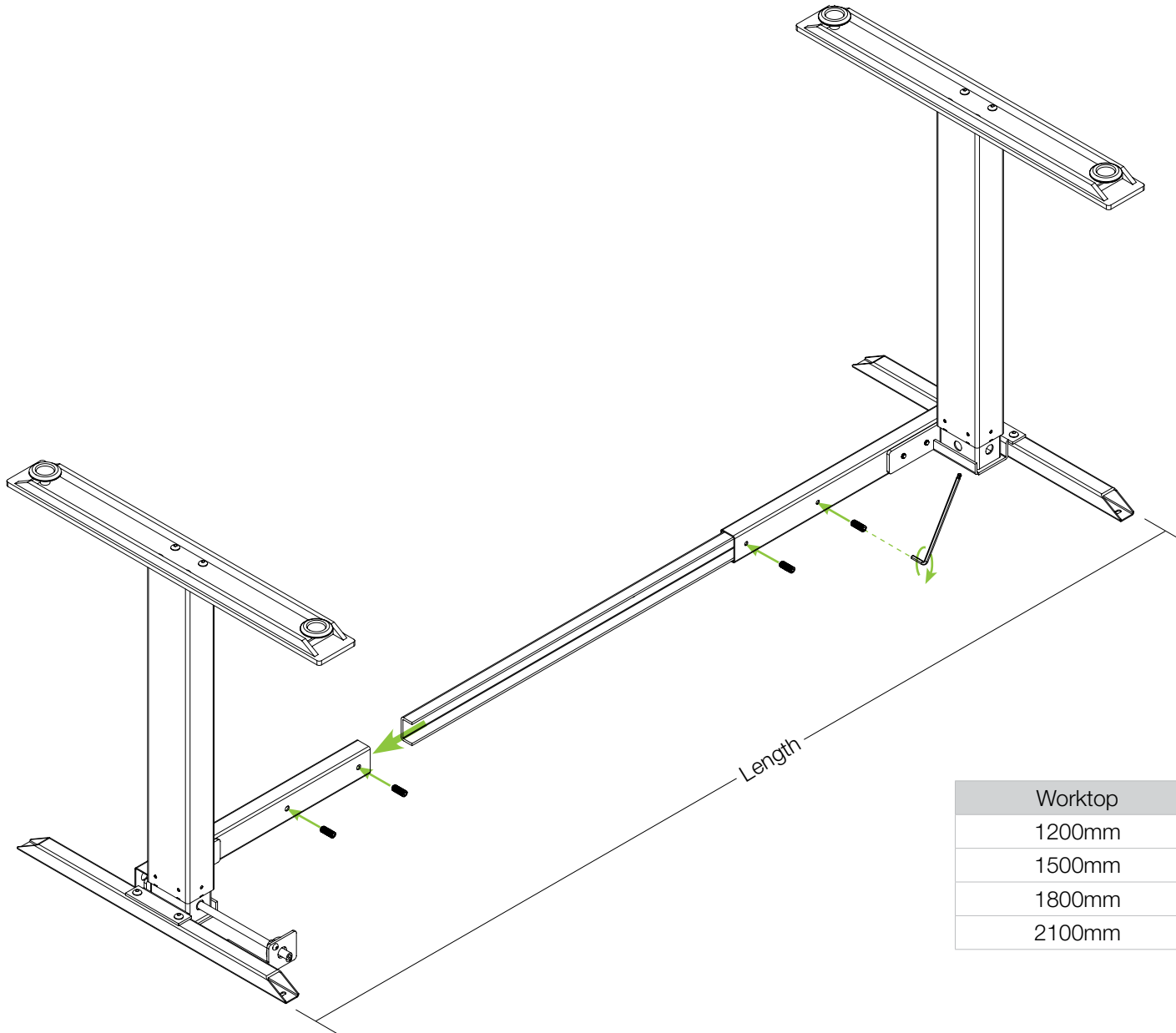

Worktop	Length
1200mm	1125mm
1500mm	1425mm
1800mm	1725mm
2100mm	2025mm

### Step 5

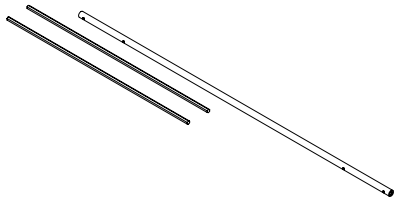

1 x Drive Shaft

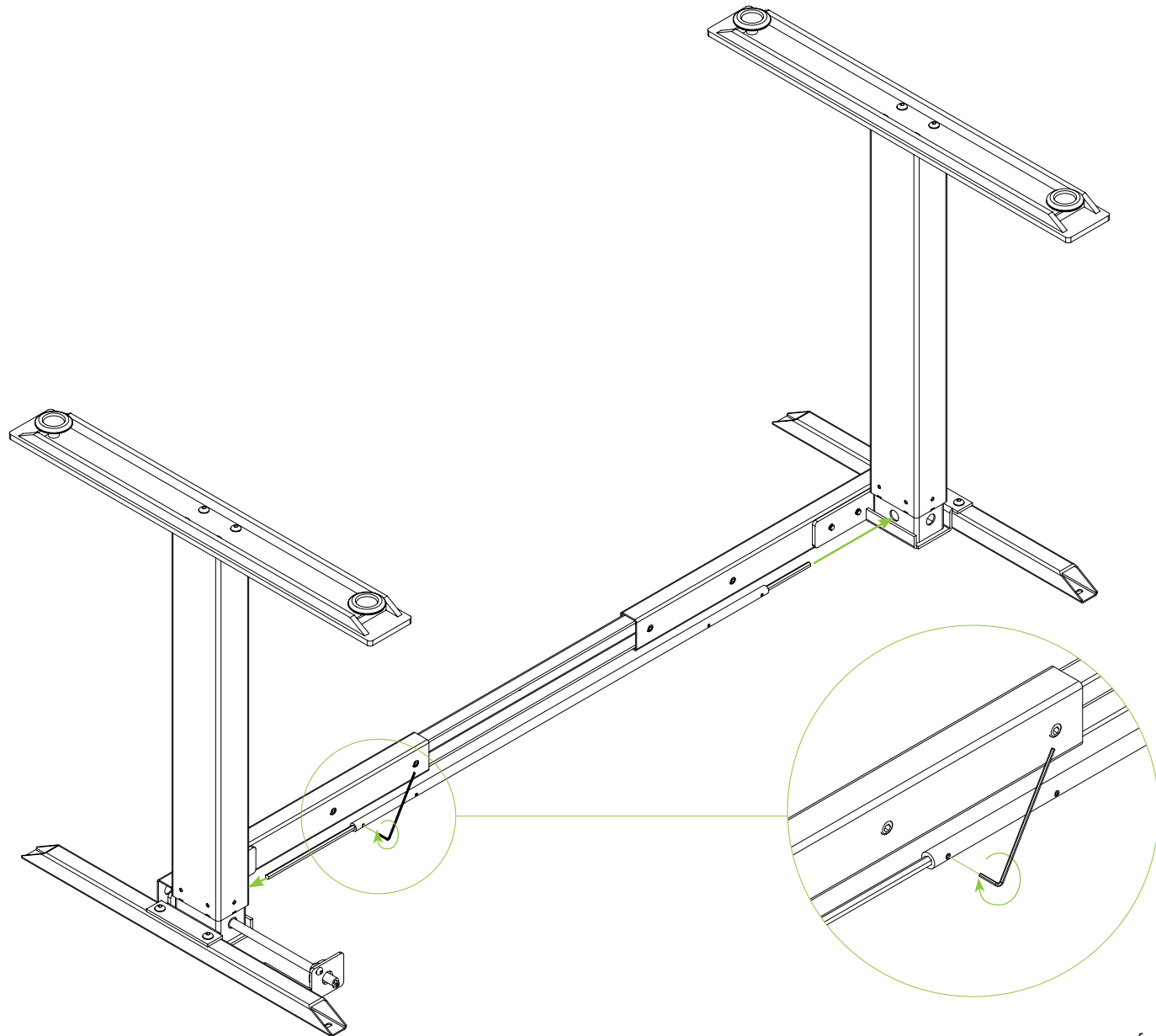

### Step 6

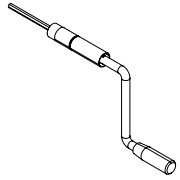

1 x Winder

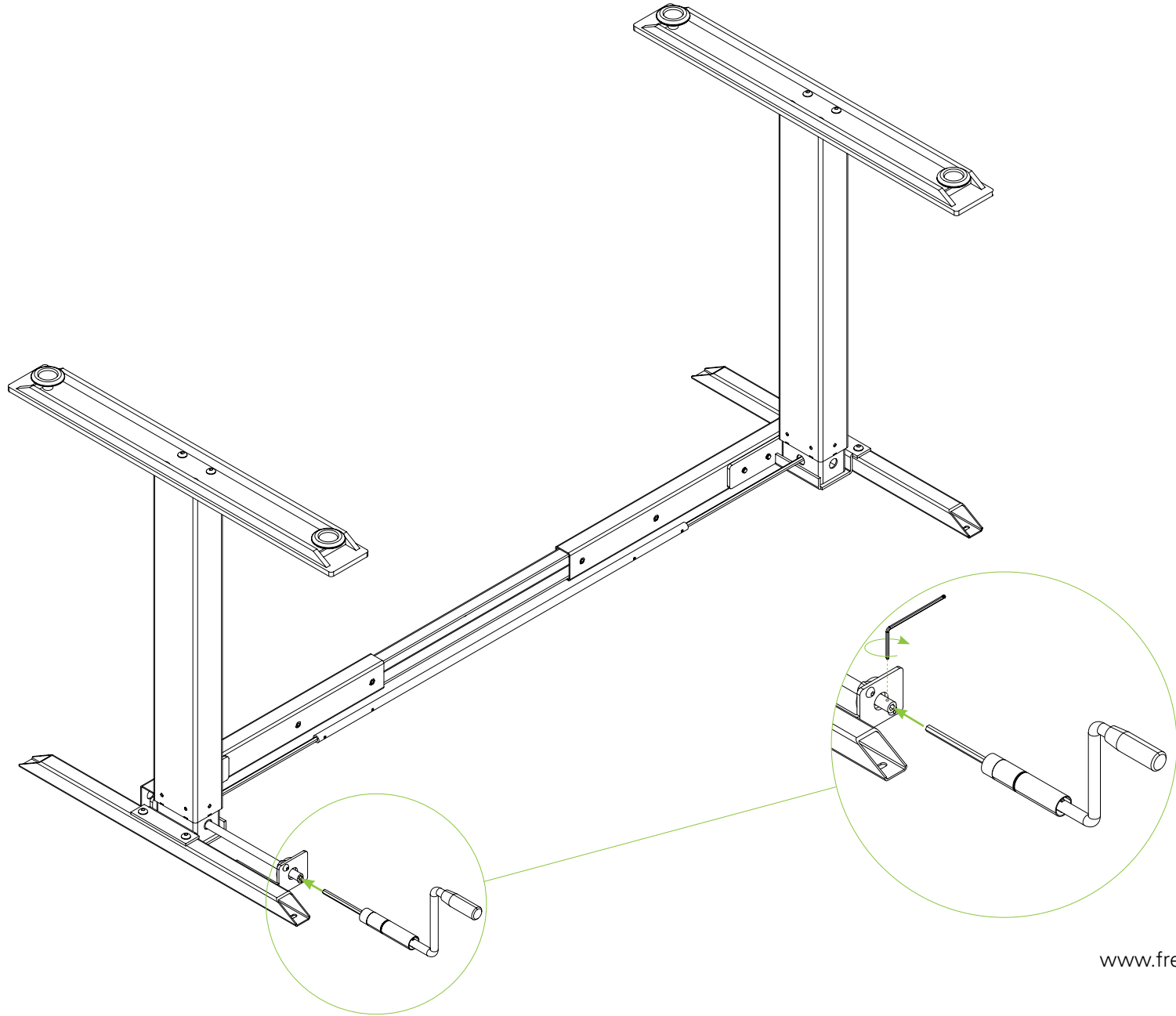



### Step 7

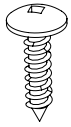

6 x ST5,0x22

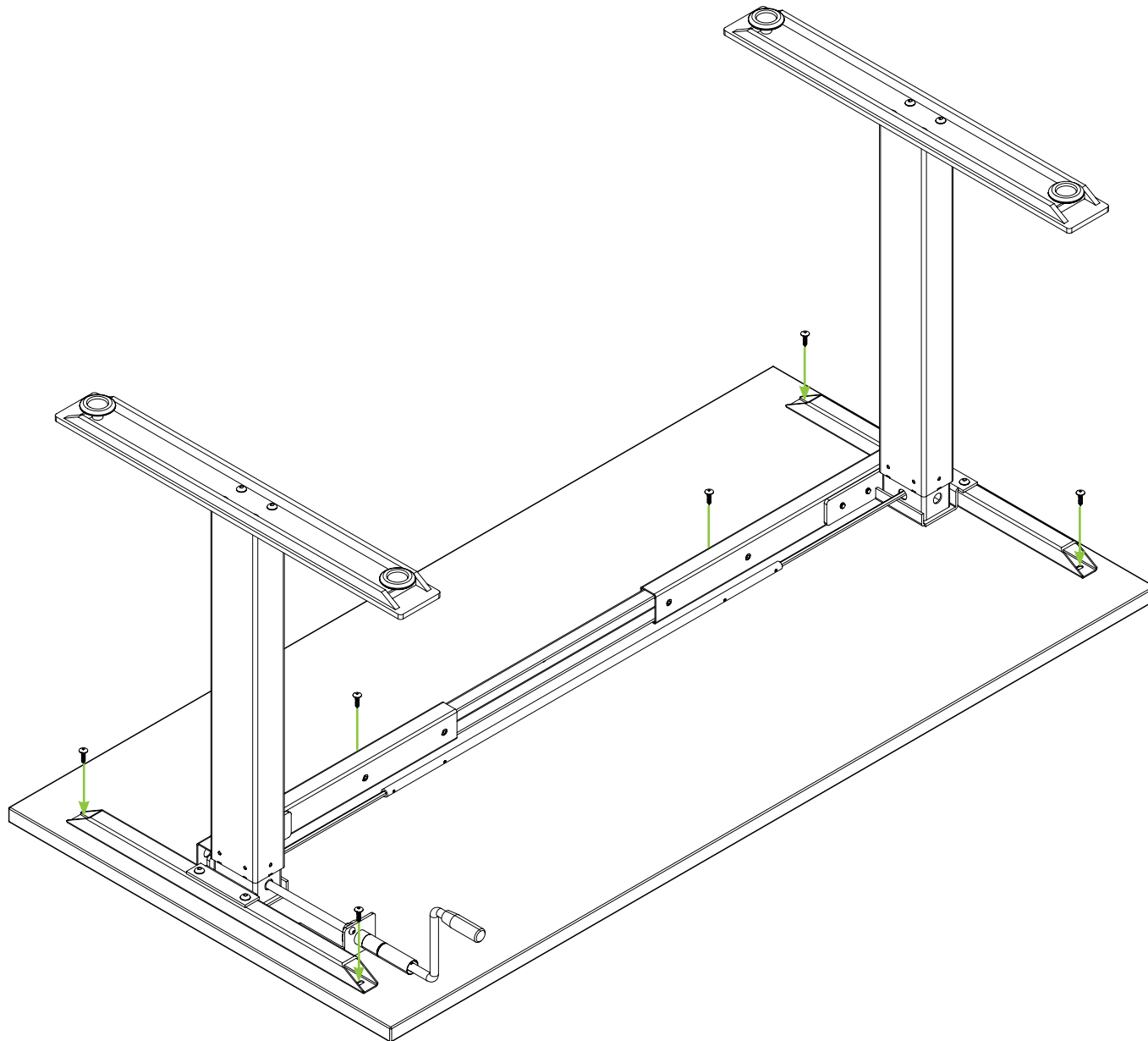

## Completed

