

# C147 Folding Table

	<b>A</b>	1pcs	<b>B</b>	2pcs	<b>C</b>	2pcs	<b>D</b>	2pcs
	<b>E</b>	1pcs	<b>F</b>	4pcs	<b>G</b>	2set	<b>H</b>	M10L60 *In object A 2pcs
	<b>I</b>	M5L30 12pcs	<b>J</b>	M4L25 24pcs	<b>K</b>	M4L12 4pcs	<b>L</b>	M6L12 8pcs
	<b>M</b>	M6L16 4pcs	<b>N</b>	2pcs	<b>O</b>	2pcs	<b>P</b>	12pcs
	<b>Q</b>	M4 *For object L 1pcs	<b>R</b>	M5 *For object I&M 1pcs	<b>S</b>	M8 *For object H 1pcs	<b>T</b>	1pcs

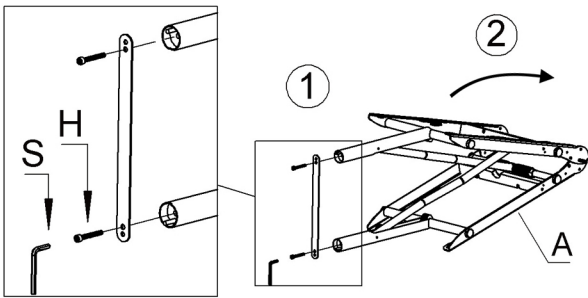

1. Open the frame (object A) carefully by releasing screws (object H).

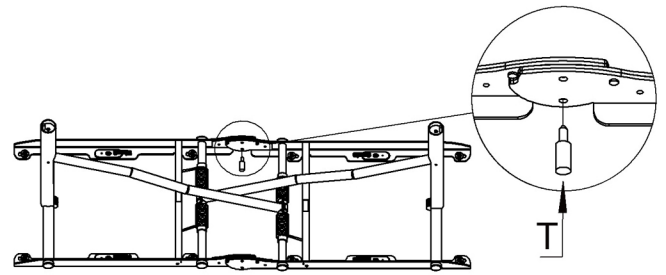

2. Insert the block pin (object T) in order to keep the frame open during the assembly.

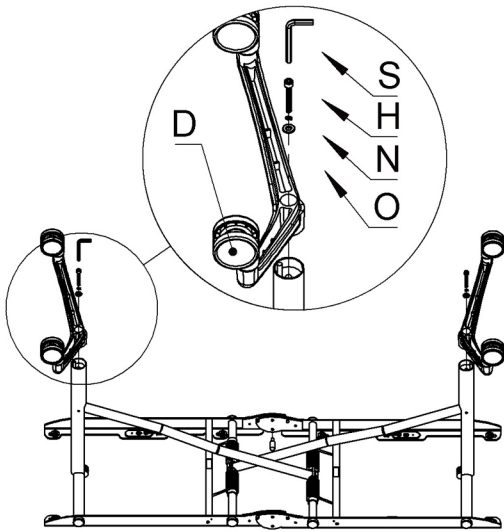

3. Setup the wheels (object D). Then turn over the frame carefully by at least 2 persons.

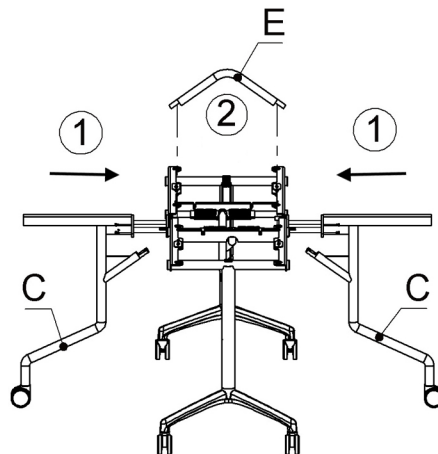

4. Setup the extra support wheels (object C). After that setup the connection part (object E)

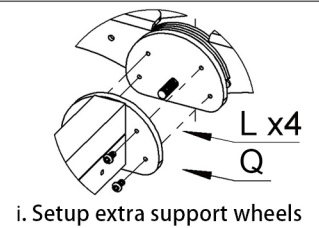

i. Setup extra support wheels



ii. Setup connection part

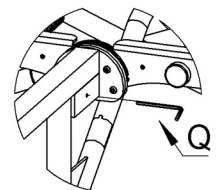

iii. Tighten the side screws of object C.

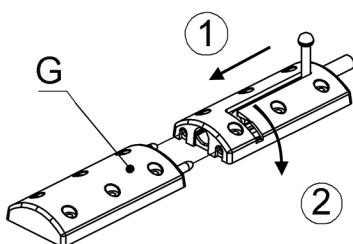

5. Setup the locks.

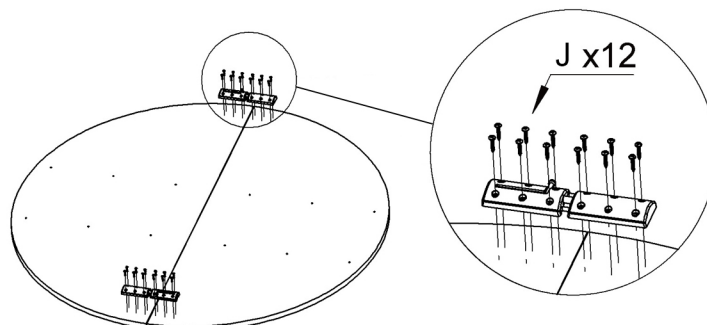

6. Put the 2 table tops (object B) together tightly and make sure they are flat. Setup the locks in the middle of the table and close to the edge as \* Picture P1 shown. Keep the locks remain closed.

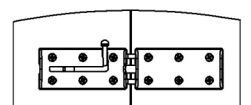

\* Picture P1

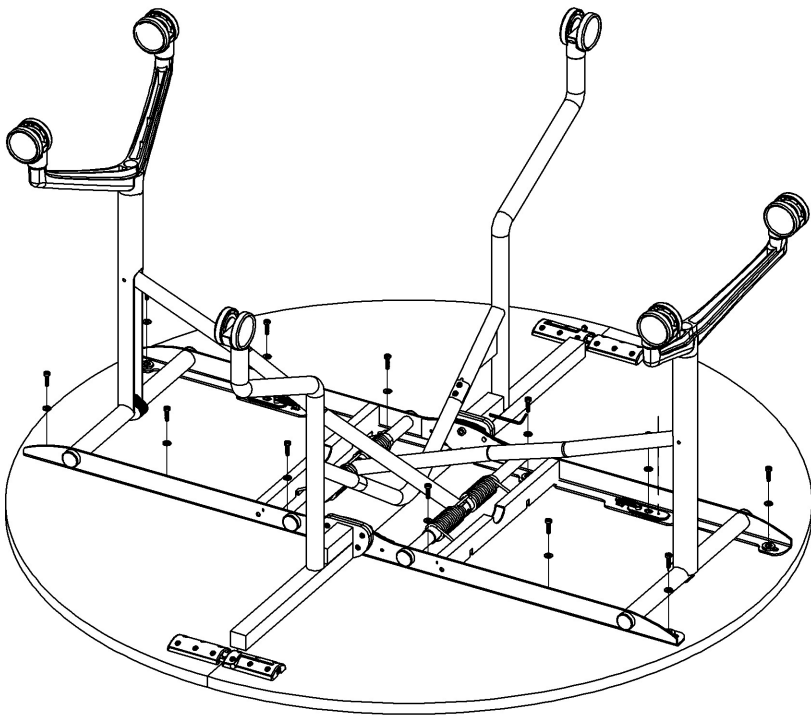

I x12

P x12

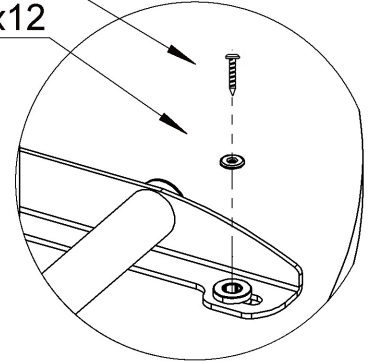

ii. Insert the 12 screws.

7. Place the frame on the table top like the picture shown above. And move all 8 plastic rings toward to the center of the table. Insert the screws then setup the 4 plastic caps.

K x4

F x4

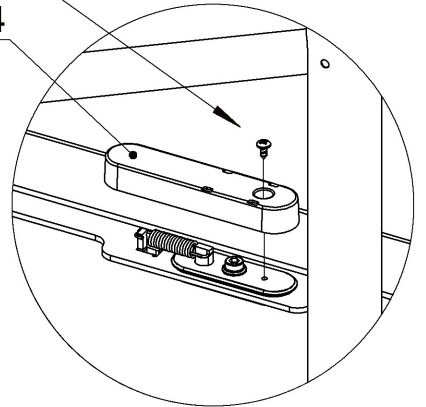

iii. Setup the 4 plastic caps.

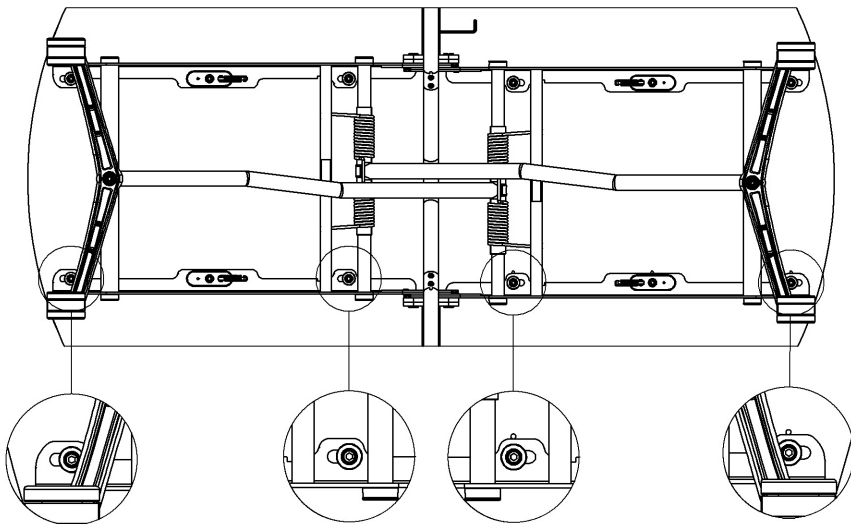

i. Move all 8 plastic tings toward to the center of the table. Make sure they are in the right position before going to the next step.

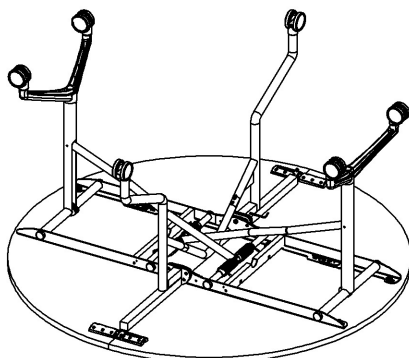

8. Turn over the table carefully by the direction that we suggested. It needs at least 4 persons to finish this step together.

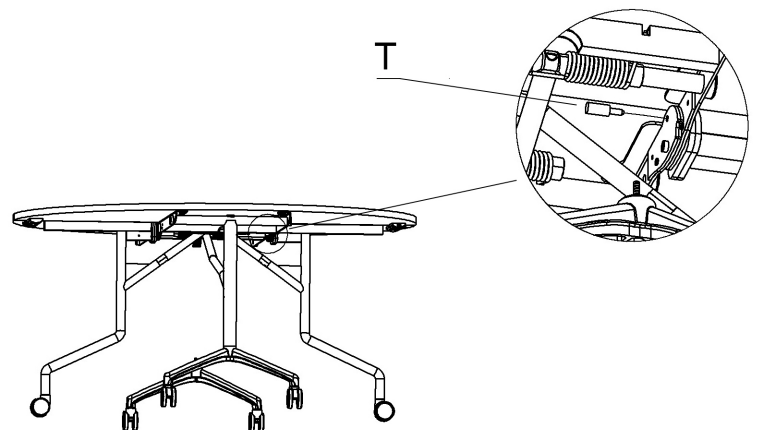

9. Take the block pin (object T) out from the bottom of table. After that, the assembly is finished.

## Unfolding

\*We strongly recommend that at least 2 people fold the table during the process.

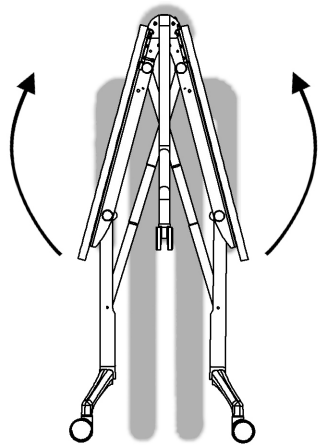

1. Unfold the table from the edges of both sides

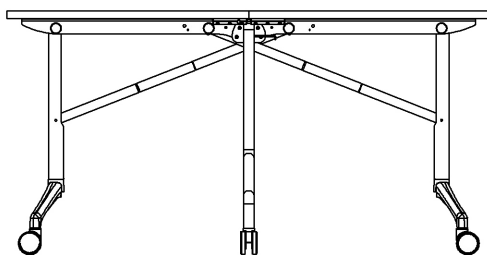

2. Keep unfolding until the table tops are turned to be flat and fit.

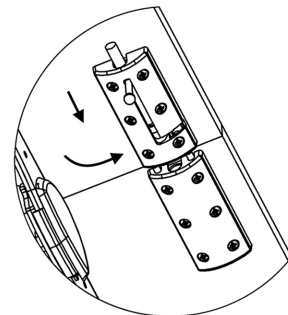

3. Lock the locks for both side

## Folding

\*We strongly recommend that at least 2 people fold the table during the process.

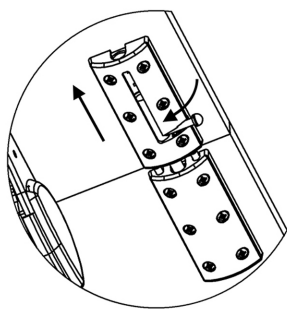

1. Release the lock for both side.

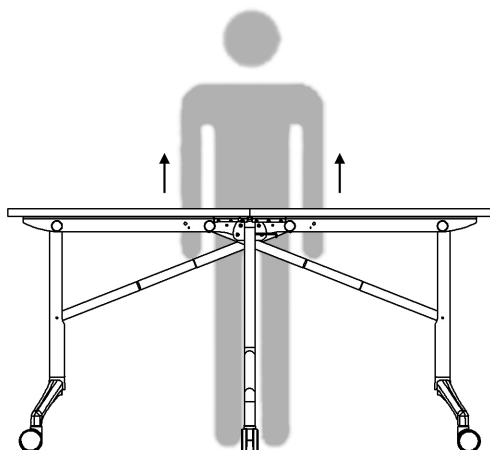

2. Fold the table from the center carefully.

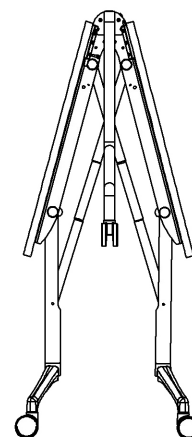

3. Keep folding until the table is completely stable.

## Caution

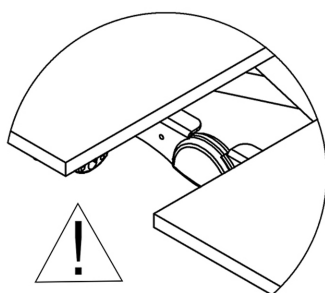

i. Don't put any objects (especially hands) between the gap when the table is unfolding.

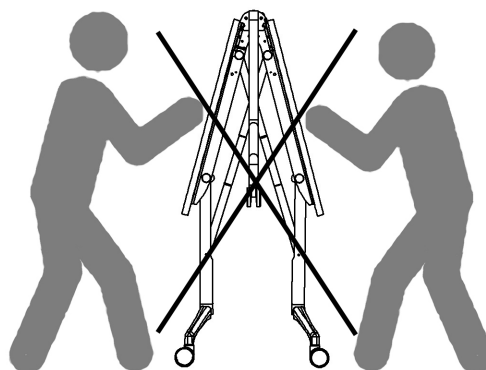
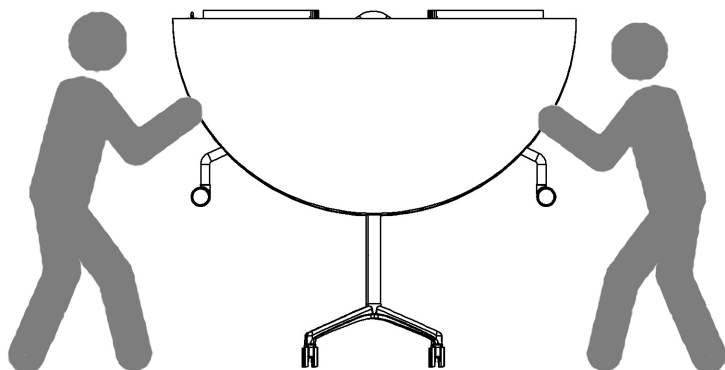

ii. When the table is folded, move it from the edge side. Don't move the table from the desktop side.