

A\*1



B\*1



C\*4

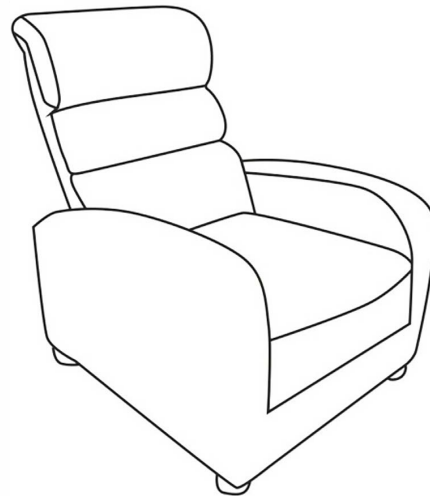
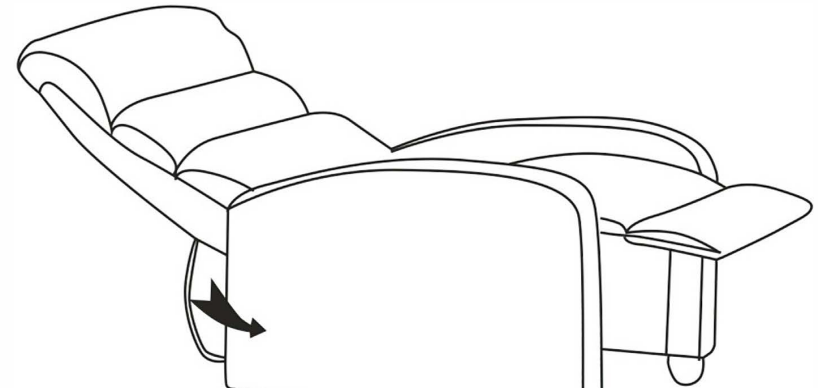
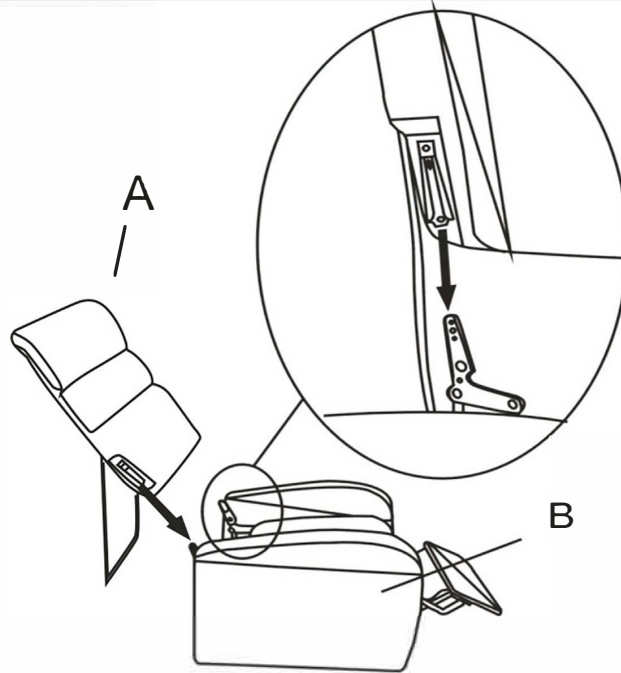

**Warning:**

This product is only suitable for one person at a time.  
 Maximum supporting weight: 150kg  
 Please keep kids away from climbing onto a recliner in case of falling off.  
 Do not use this recliner as a step ladder or stand on it.  
 Please check all bolts, screws and knobs every 4 months. Only use this product when they are all secured firmly.  
 Please stop using this product, if any parts are missing, broken or damaged and contact authorised company for parts.  
 Failure to follow these warnings could result in serious injury.