

Agile

Installation Guide - Electric 2 Column

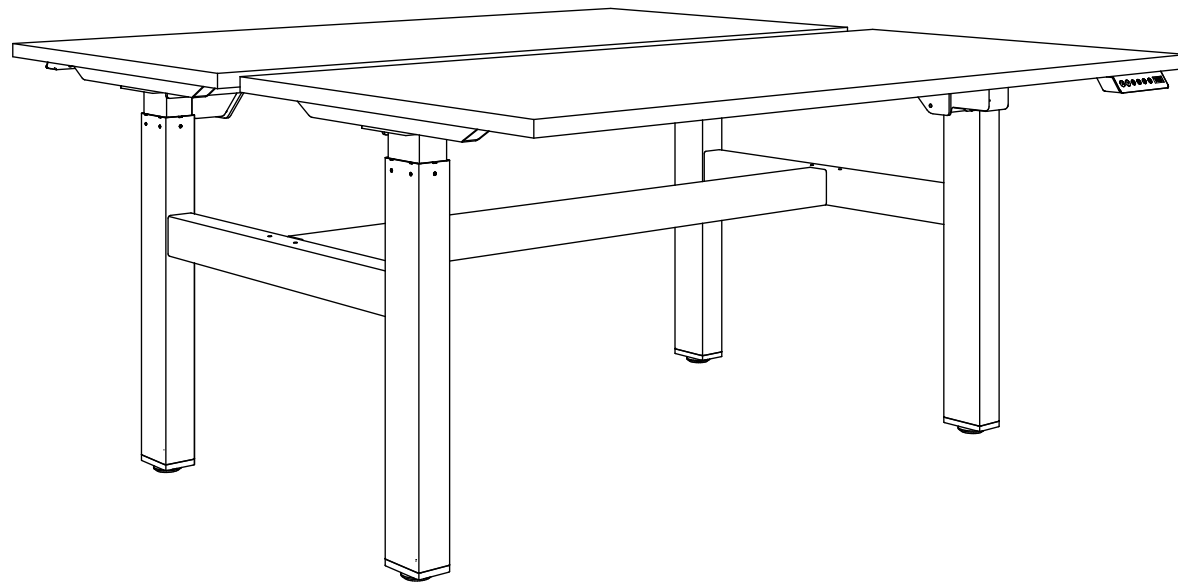

freeway



Parts:

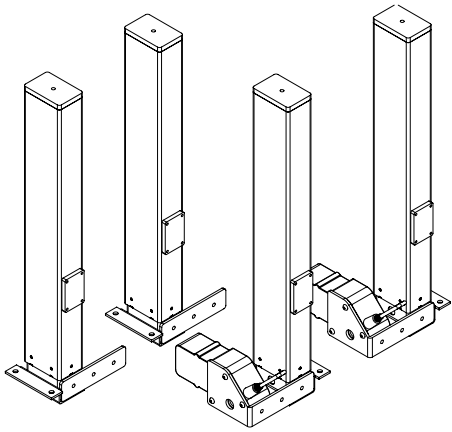

2 x L&R Leg Pair

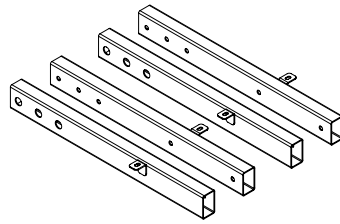

2 x L&R Leg Rail Pair

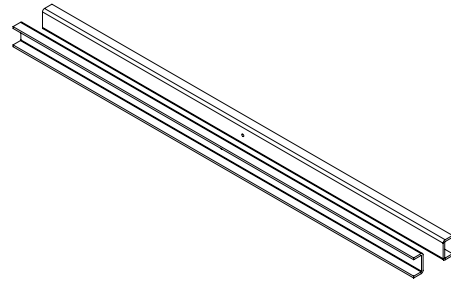

2 x Cross Rail

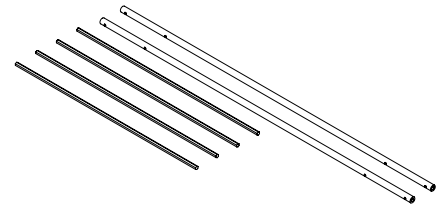

2 x Drive Shaft

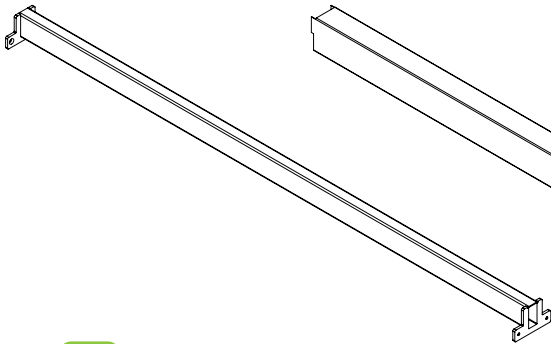

1 x Cross Beam

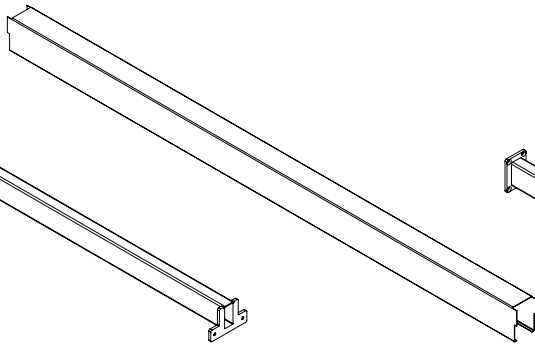

1 x Cross Beam Cover

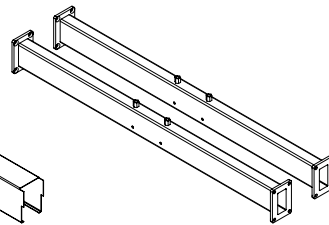

2 x Leg Beam

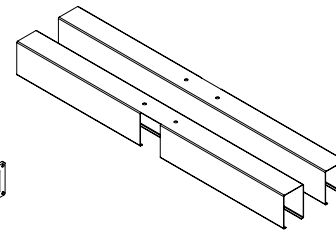

2 x Leg Beam Cover

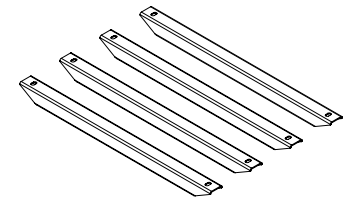

4 x L&R Support Bar

Parts:

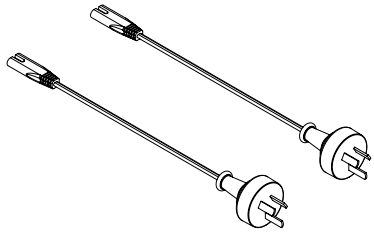

2 x Power Cord

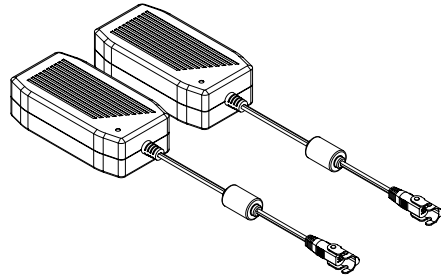

2 x Power Supply

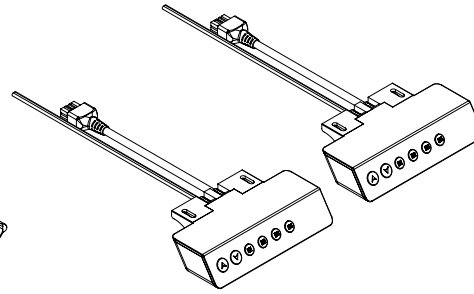

2 x Handset

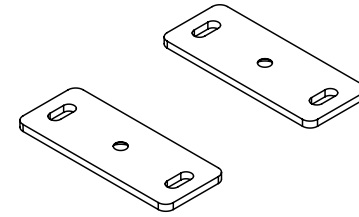

2 x Screen Bracket

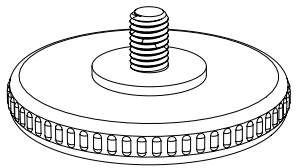

4 x Levelling Foot

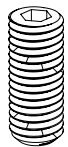

8 x M10x25



20 x M8x10

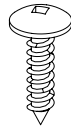

20 x ST5.0x23



4 x ST3.9x13

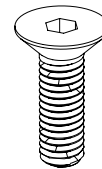

2 x M8x20



4 x M5x15



20 x M5x10

Step 1



12 x M8x10

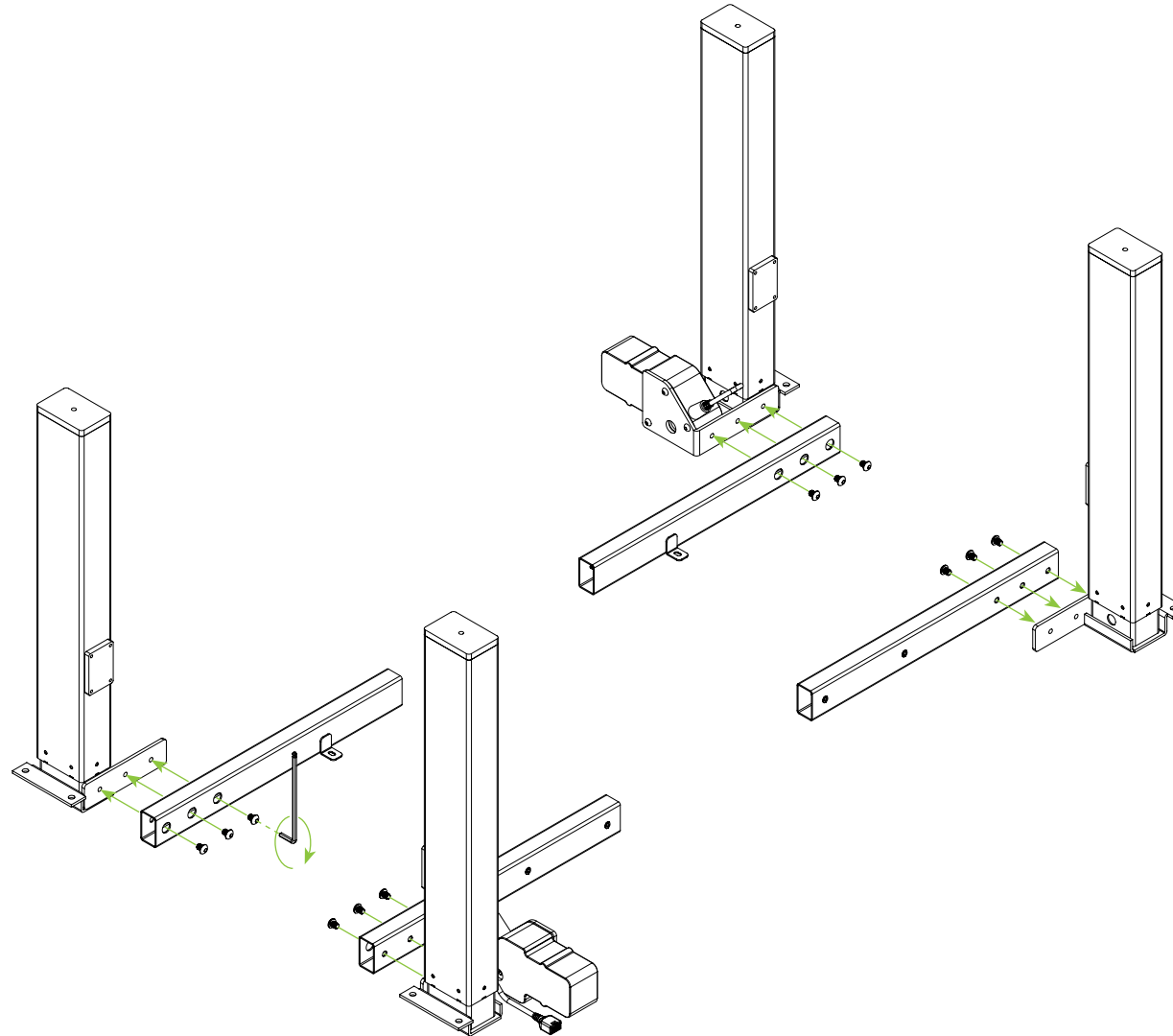

Step 2



8 x M8x10

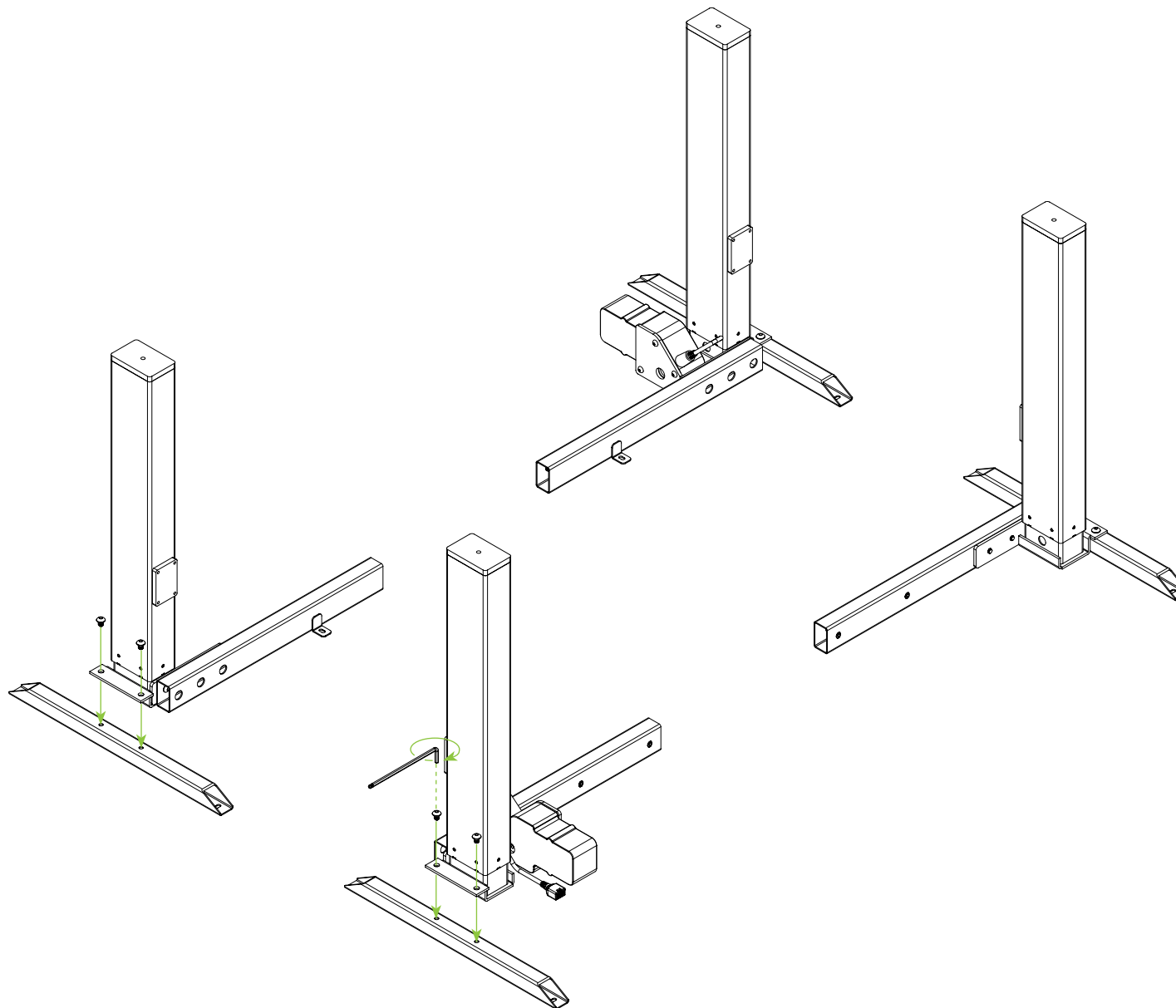

Step 3

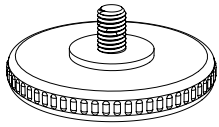

4 x Levelling Foot

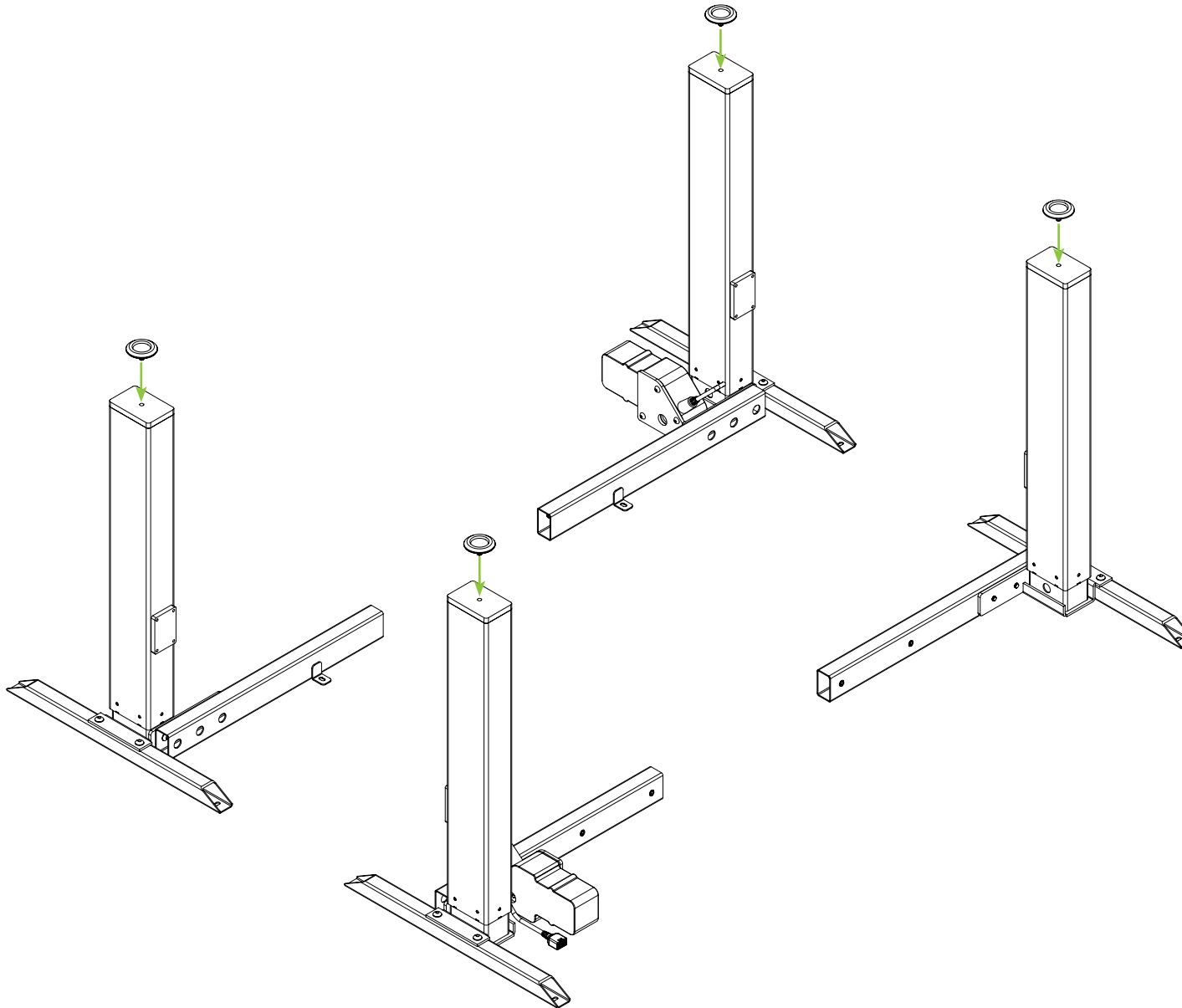

Step 4



16 x M5x10

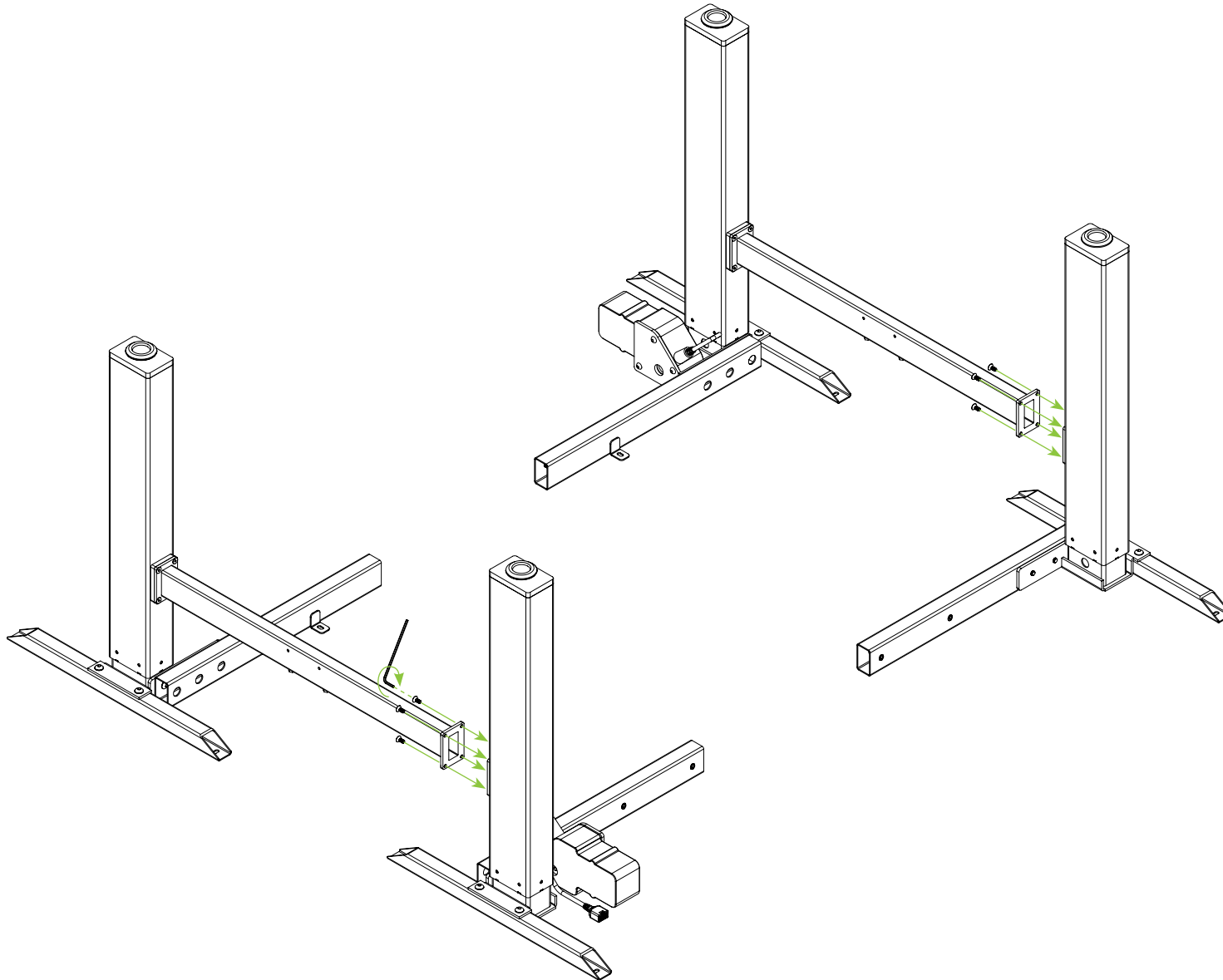

Step 5

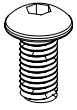

4 x M5x10

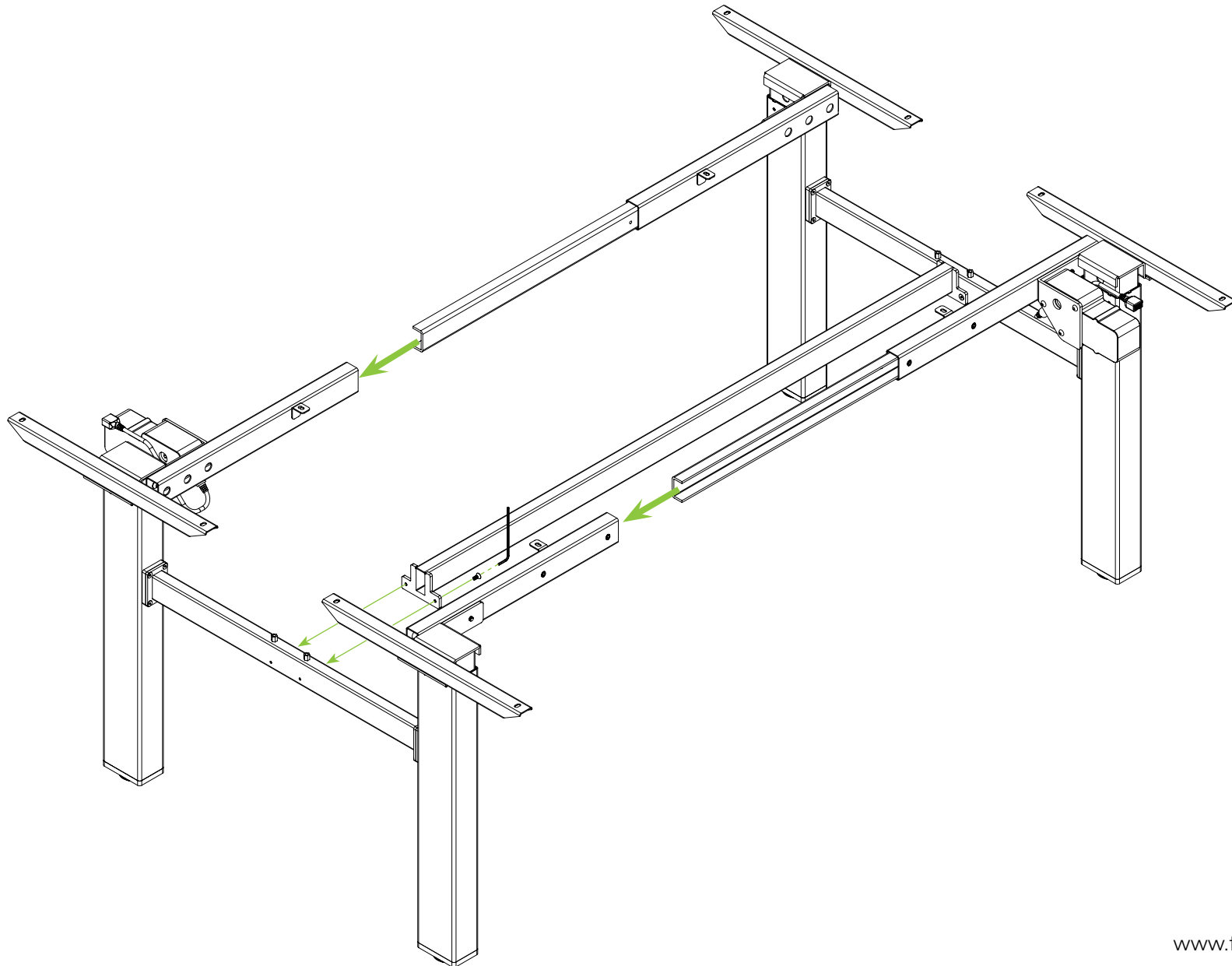

Step 6



8 x M10x25

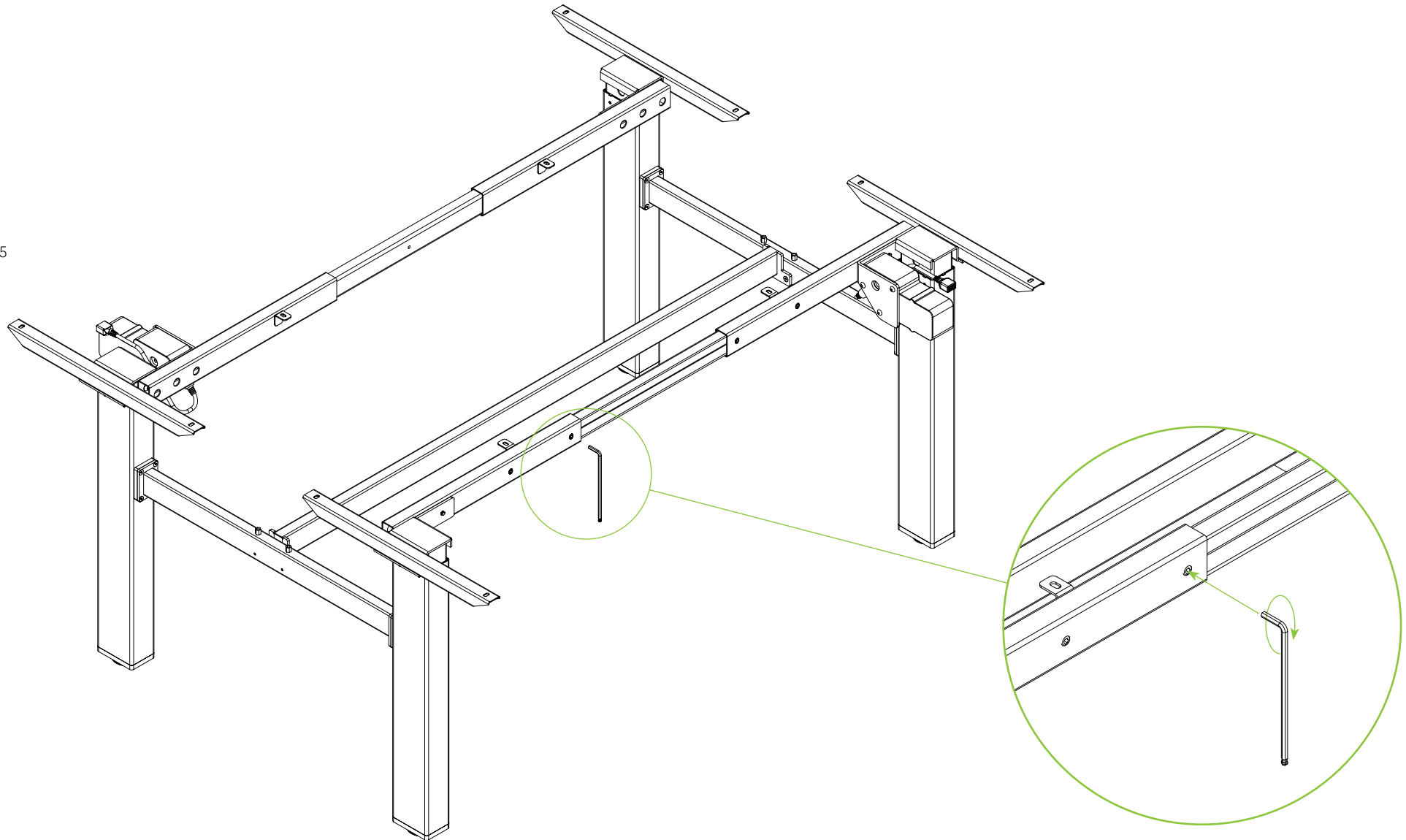

Step 7

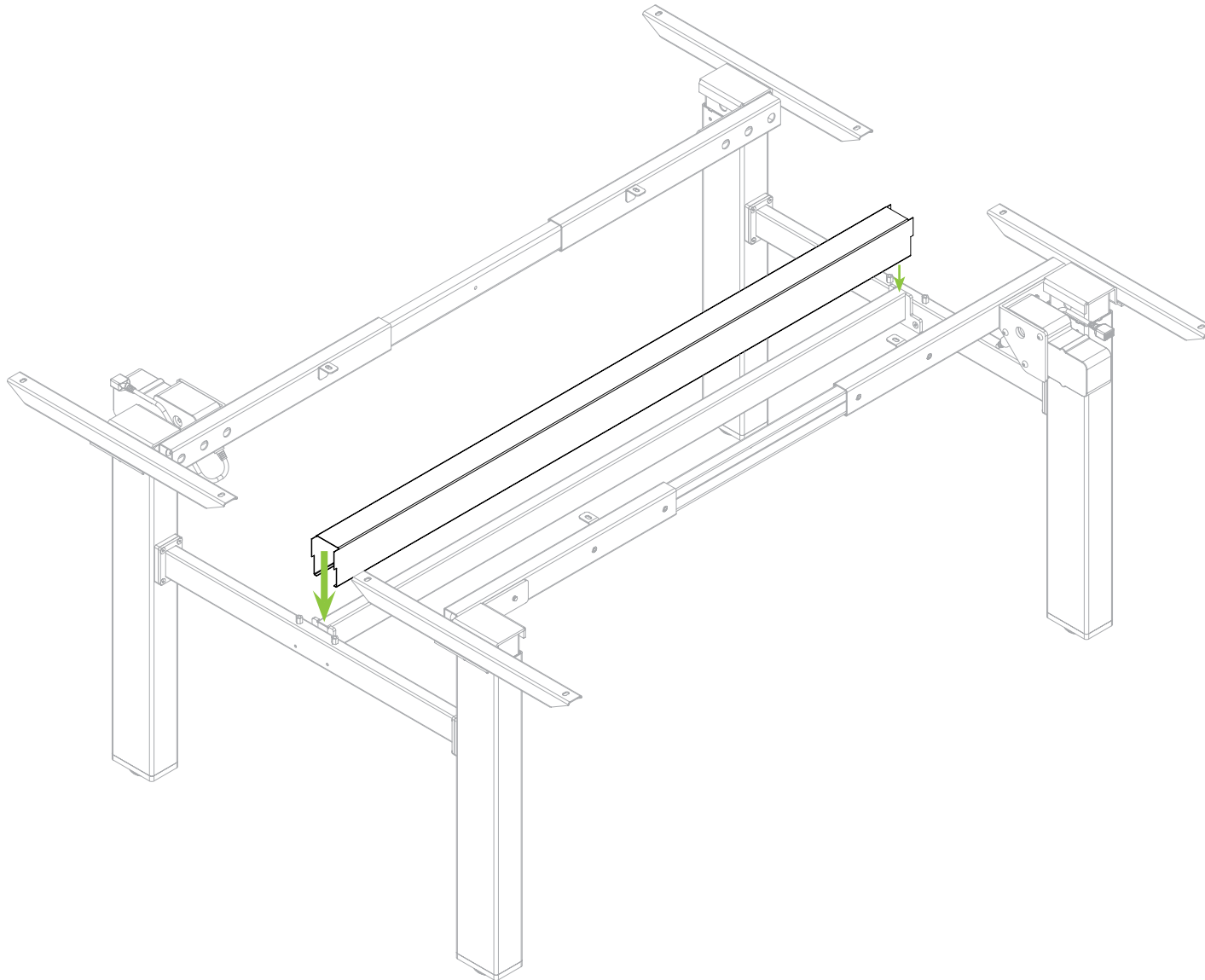

Step 8

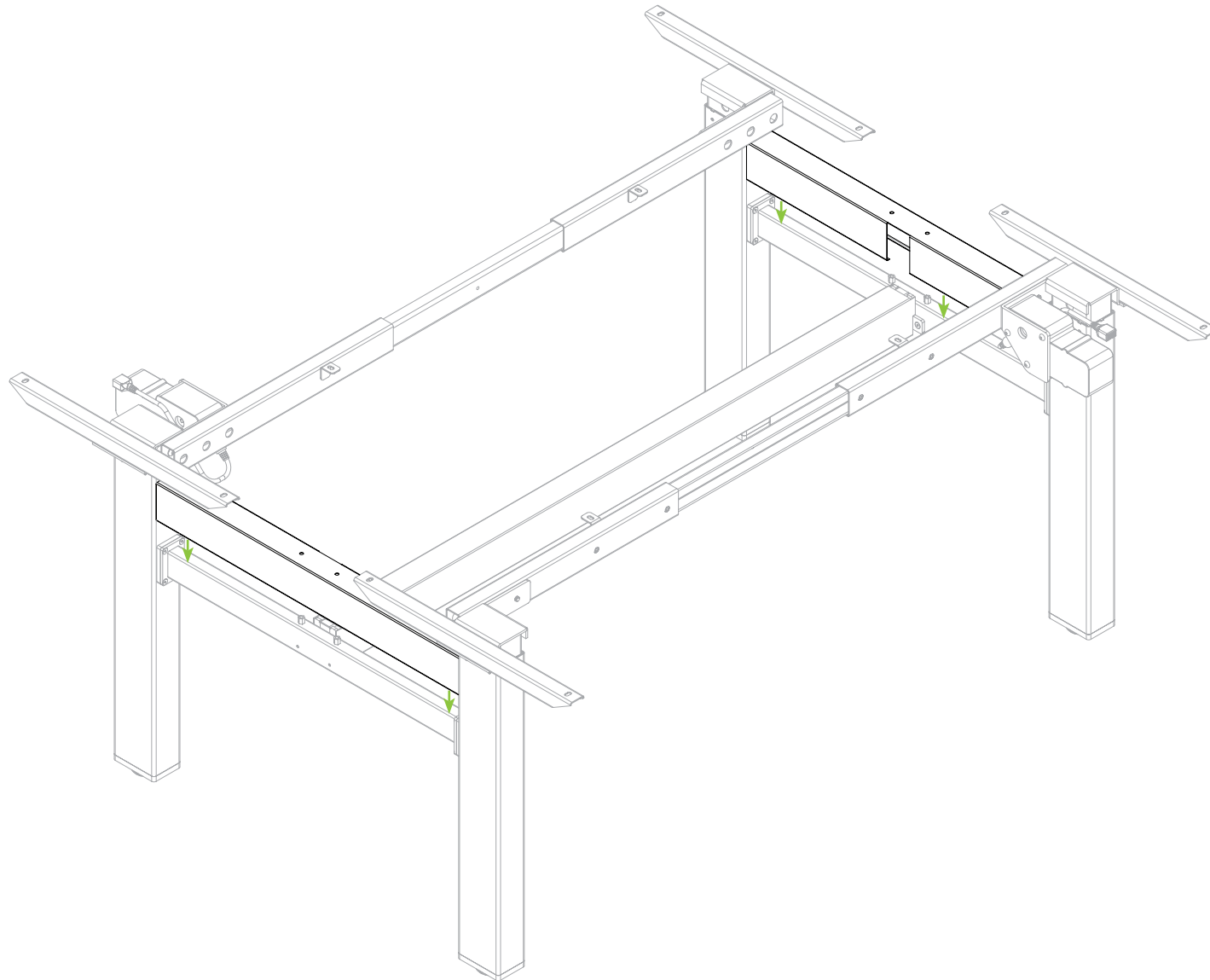

Step 9

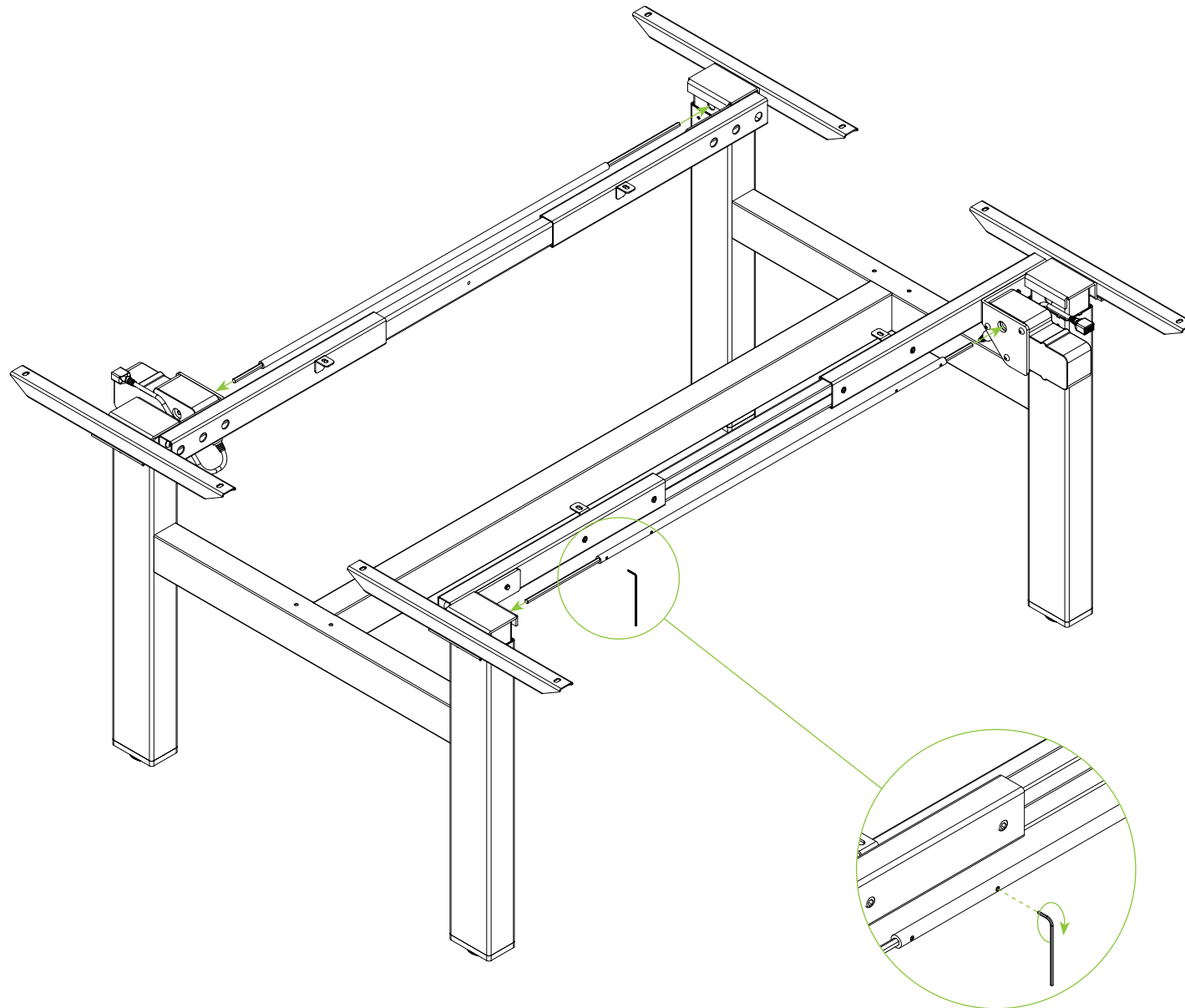

Step 10

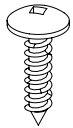

12 x ST5.0x23

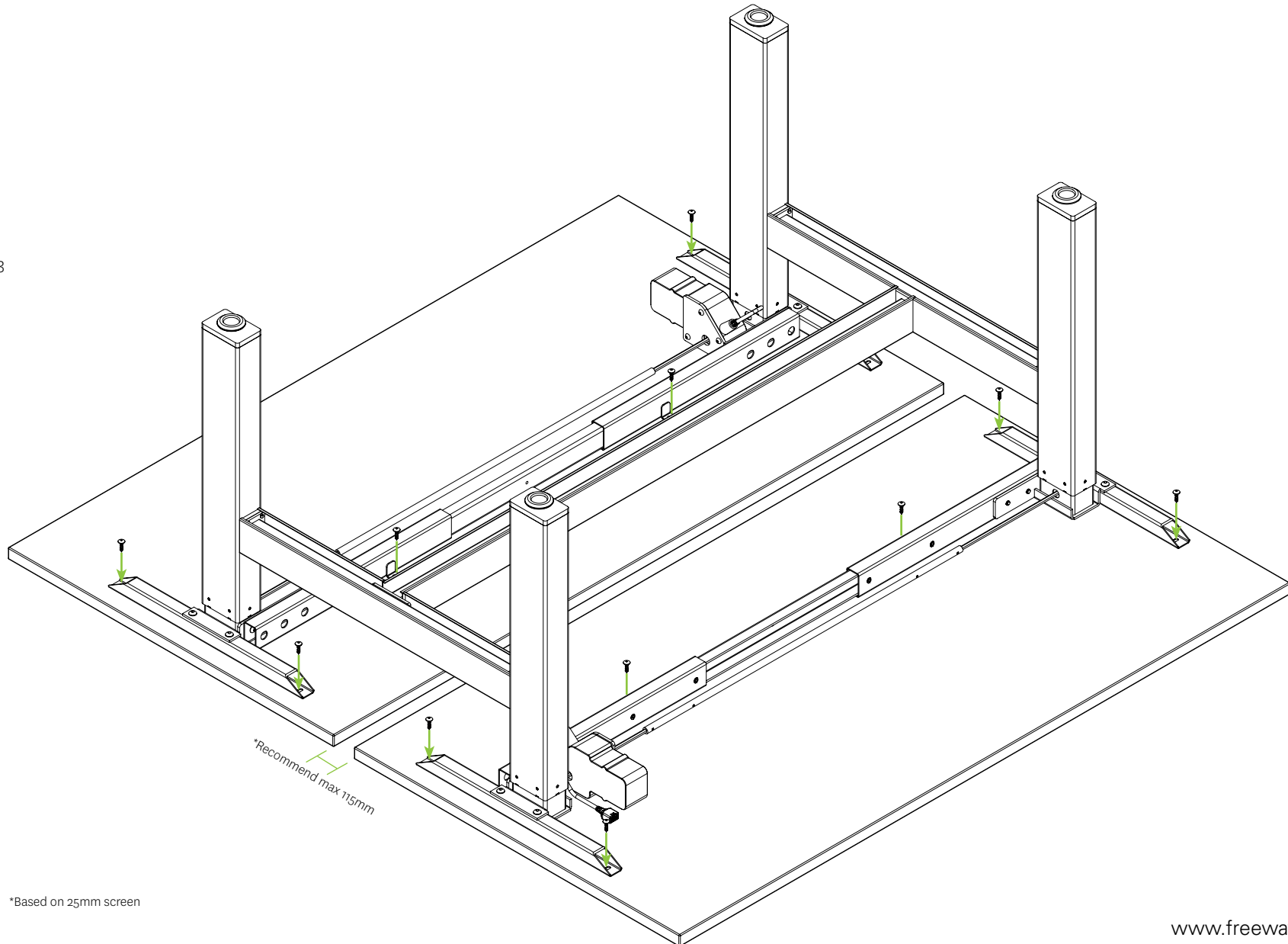

*Recommend max 115mm

*Based on 25mm screen

Step 11

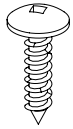

4 x ST3.9x13

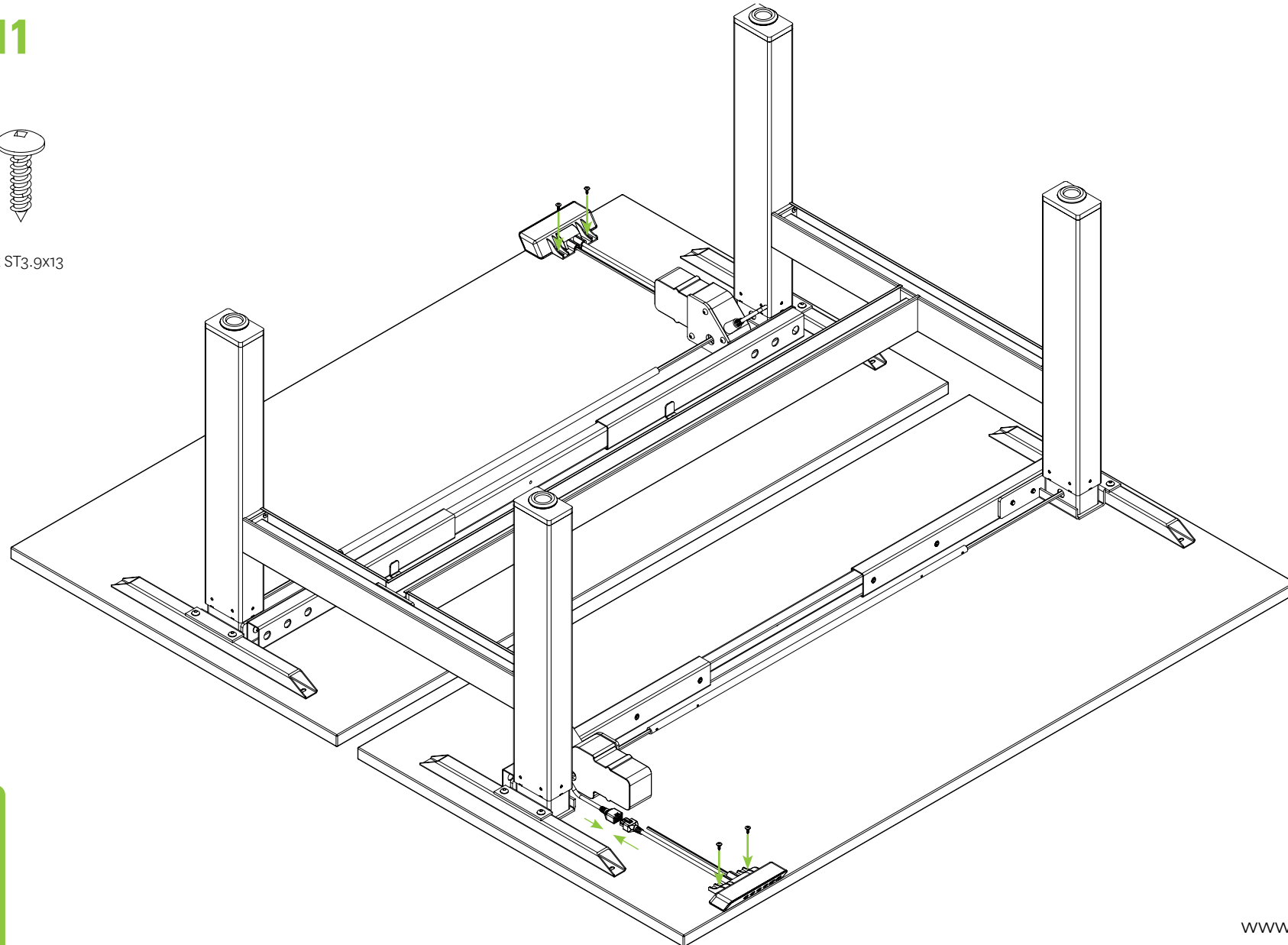

Step 12

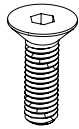

2 x M8x20

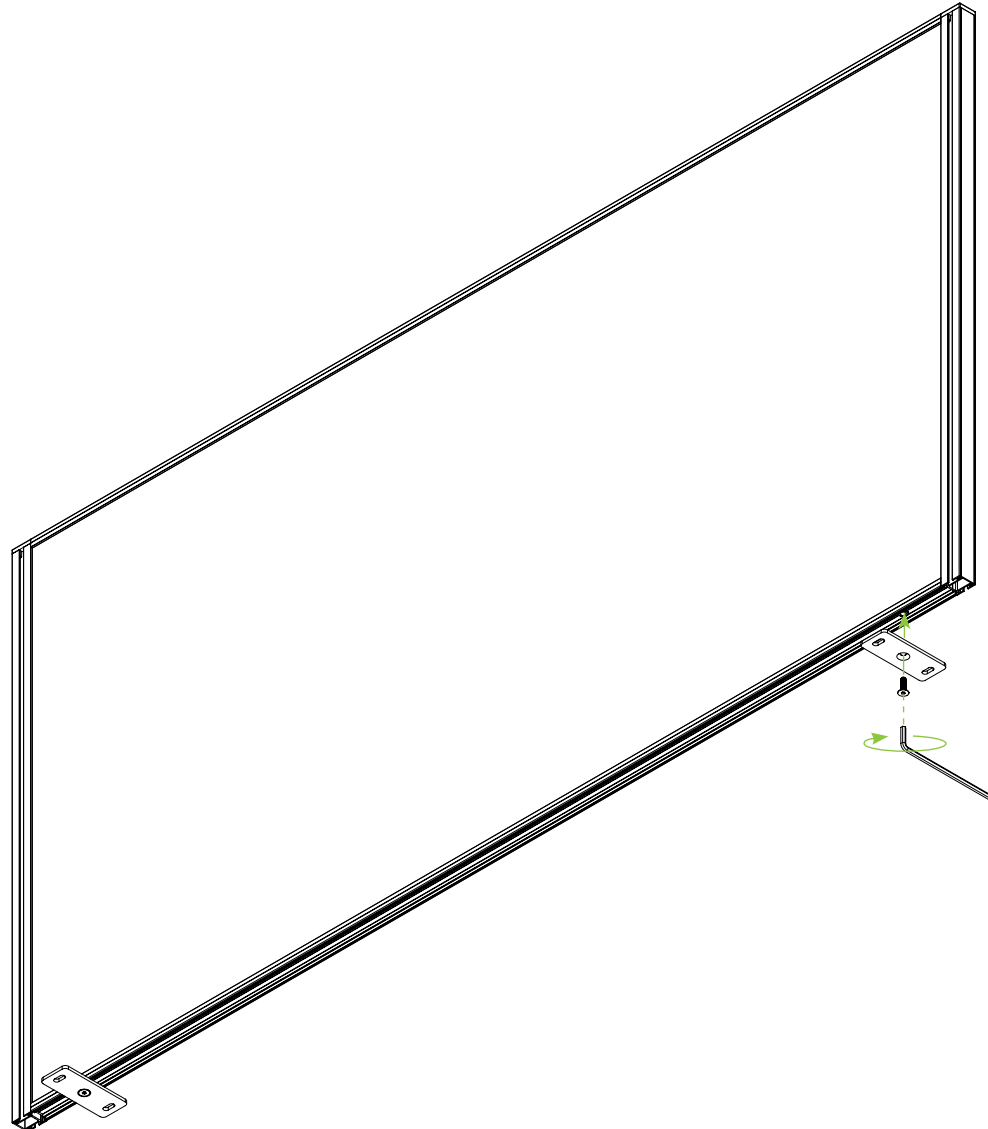

Step 13

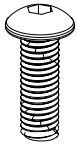

4 x M5x15

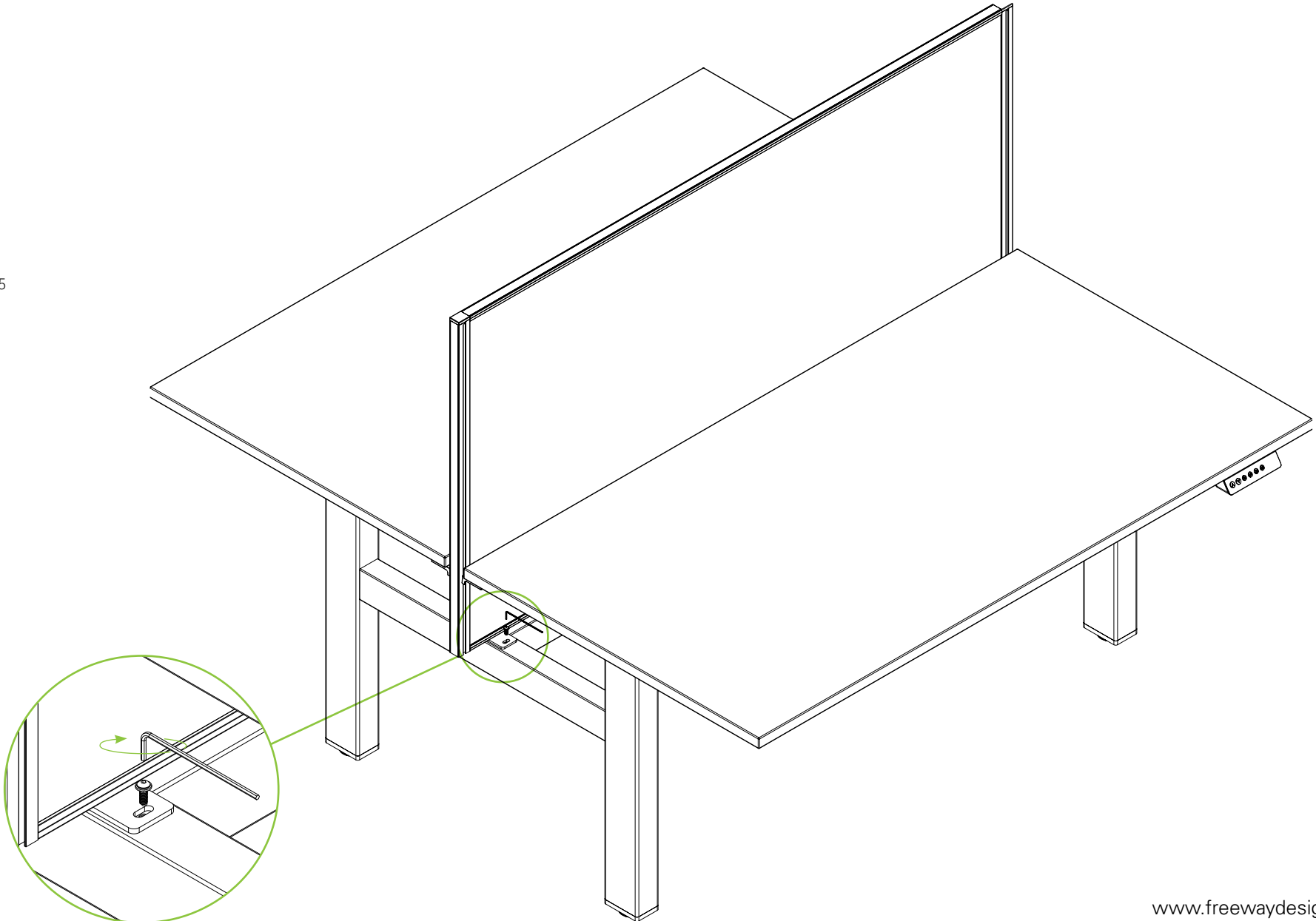

Step 14

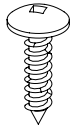

8 x ST5.0x23

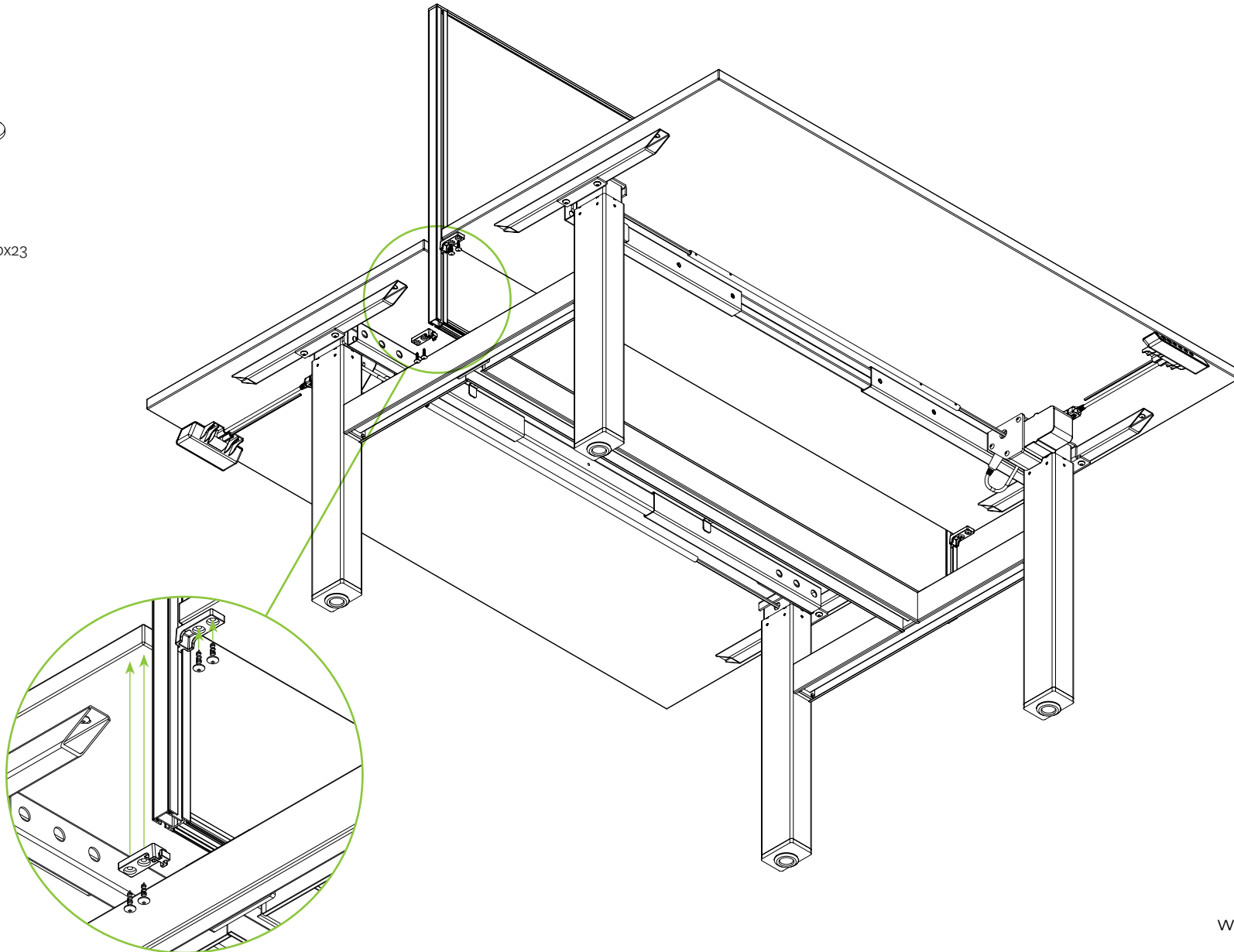

Step 15

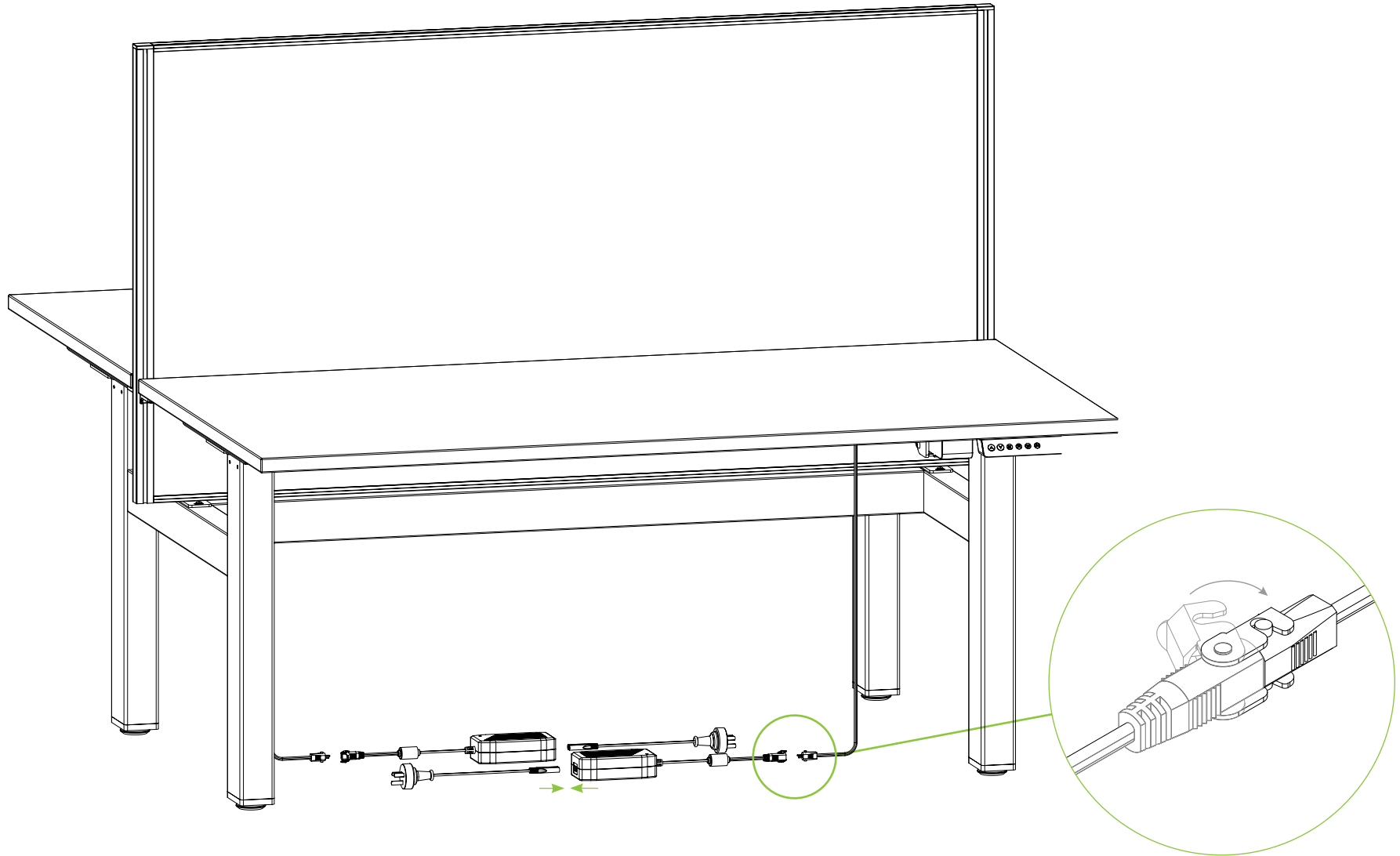

Completed

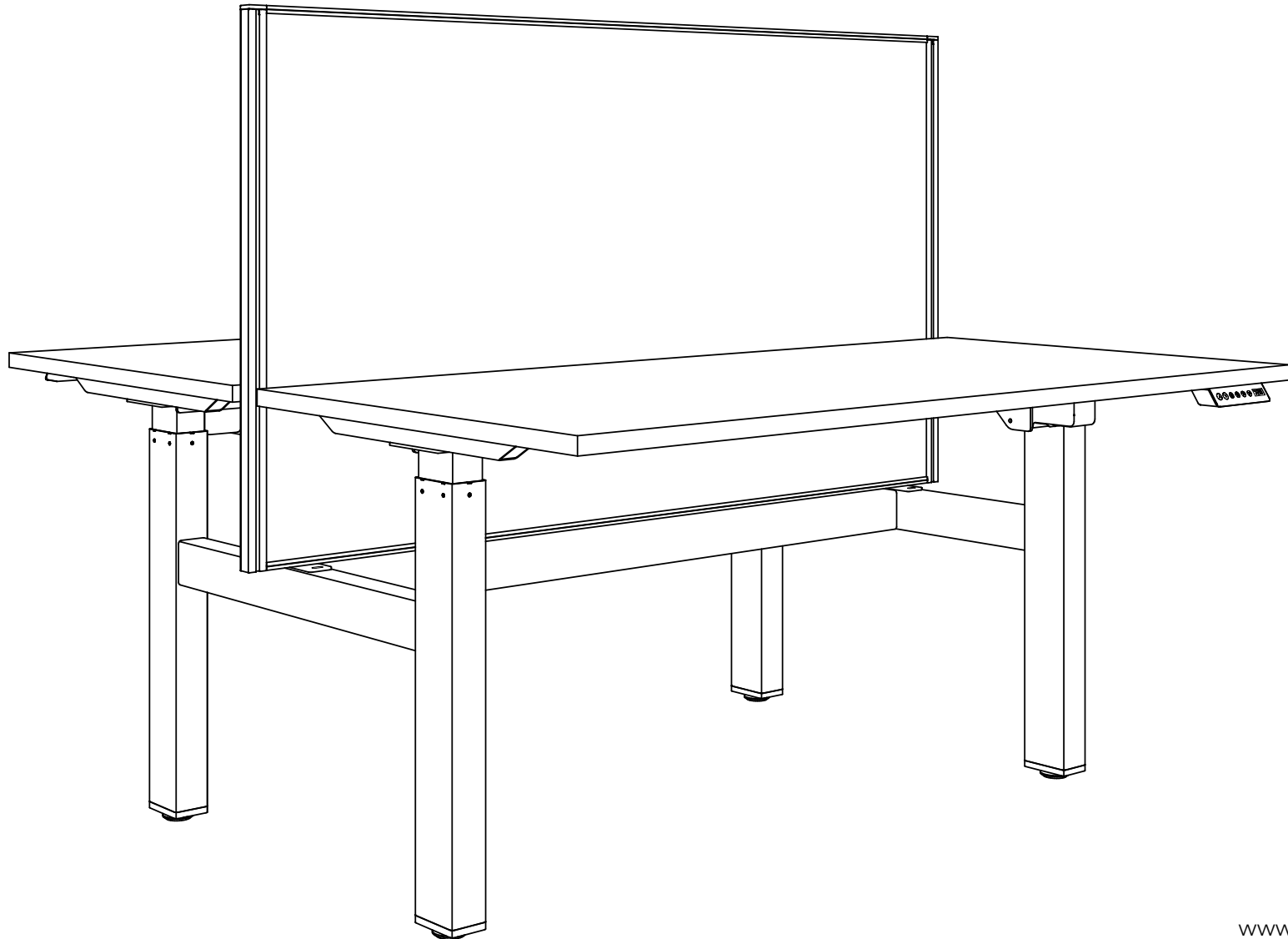

IMPORTANT NOTES!

Prior to instalment, use and maintenance of the table frame, any installer and any user of the table must study this assembly and operation manual carefully, so as to gain a complete understanding of its contents.

WARNING: FAILURE TO COMPLY WITH OR OBSERVE ALL ASSEMBLY, SAFETY AND OPERATION INSTRUCTIONS AND WARNINGS REGARDING THE USE OF THIS PRODUCT MAY RESULT IN SERIOUS BODILY INJURY.

SAFETY AND WARNINGS

- This table complies with the prescribed safety regulations. Inappropriate use may cause damage to persons and table.
- Please read the operation manual prior to start using the table. It provides you with important information about safety, use, installation and maintenance of the table, and thus protecting you and your children and avoiding damage on the table.
- Please guard this operation manual and pass it on to any future owner!

USAGE

- The electromotive, height-adjustable tables are designed for workstations in dry work environments only. The table height is infinitely adjustable, so that it can be set to the most ergonomically suitable working level.
- They have not been designed for other purposes than those included in this manual, e.g. they are not to be used in areas of high humidity or dampness, nor for lifting people. Any other use is at one's own risk!
- Do not crawl, lie or move around under the table frame, and do not sit or stand on the table frame.
- CHILDREN should only use the table when supervised by adults.
- Liability: The manufacturer accepts under no circumstances warranty claims or liability claims for damages arising from improper use or handling of the table frame other than that described in this operation manual.

SET UP AND INSTALLATION

When the table has been assembled (see assembly instructions on page 3-4) the adjustable feet are installed so that the table is level and does not shift. Then the table is connected to the 110-230 VAC outlet and the table is ready for use.

- Make sure that no cables can get jammed.
- Place the table in a safe distance from window frames, radiators, furniture etc. so that people do not get stuck.
- Do not place any objects above 55 cm underneath the table.
- When moving the table after it has been assembled, the table top needs to be removed. The table **CANNOT** be lifted by the table top.

Directions For Use

MAINTENANCE AND DEFECTS

- The table does not require any maintenance by usage as described in chapter 2 in the directions for use.
- The table is only to be maintained with a wrung cloth.
- In the event of the occurrence of jarring sounds during operation, STOP using the table and please contact the dealer.

TECHNICAL DATA

Frame material & weight: Steel ~37kg
 Worktop Length: 1200-1700mm, 1500-2100mm
 Worktop Depth: 600-900
 Height Range: 680-1160mm
 Speed: ~20mm/s
 Max Load: 100kg
 Input Voltage: 100-240V AC 50-60Hz
 Output Voltage: 24V DC 2.0A
 Duty Cycle: 10% 2min on 18min off

